

Table of Contents

1	Read this First	1
	Safety.....	1
	Declaration of Conformity (EU only).....	1
	About this manual.....	1
2	How this Help Works	3
	Help Menu.....	3
	User Guide.....	4
	Remote Assistance (optional).....	5
3	Meet your Document System	6
	Introduction.....	6
	System Overview.....	7
	Operating Controls.....	9
	Control Panel.....	10
	How to Operate the Touch Screen.....	11
	Use a Web Browser.....	12
	What is a Job?.....	13
	Job List.....	14
	Job Overview.....	15
	High Capacity Document Feeder (HCDF).....	19
	MaxiFeeder.....	20
	VersaFeeder	21
	High Capacity Conveyor Belt.....	22
	Catch Tray for Side Exit.....	23
	Power Stacker Support.....	24
	Automated Insertion Management System (AIMS).....	24
	Shut Down the System.....	24
4	Working with Jobs	25

Introduction.....	25
Use an Existing Job.....	25
Create a New Job.....	26
About Automatic Jobs.....	27
Create an Automatic Job.....	27
Create a Manual Job.....	28
Create a test mail set.....	41
Mail Sets.....	46
Change to Another Feeder Tray.....	50
Link Feeder Trays.....	51
Edit a Job.....	51
Save a Job.....	52
Delete or Move an Enclosure.....	53
Copy a Job.....	54
Delete a Job.....	54
Rename a Job.....	55
Lock a Job.....	55
5 Loading the System	57
Document Orientation.....	57
Document Feed Trays.....	58
Load Envelopes.....	72
Filling the Sealing Liquid Reservoir.....	74
6 Settings menu	76
Open the Settings Menu.....	76
The Settings Menu Supervisor.....	77
Supervisor Settings Menu.....	78
7 Connect the System to the Internet	98
Options for Connection.....	98
Set up a Wired Connection.....	98
Set up a Wireless Connection.....	100
Test the Connection.....	102

	AIMS settings.....	102
8	Reading	103
	Introduction.....	103
	BCR Code Description.....	104
	OMR Code Description.....	110
	Flex Reading Code Description.....	115
	Create Jobs with Reading.....	115
	Reading Settings.....	120
	Exit Selection with Reading.....	122
9	Operator Maintenance	124
	Maintenance Schedule.....	124
	Clean and Replace Brushes.....	125
	Replace or Clean Moistening Cloth.....	126
	Calibrate Photocells.....	127
10	Fault Finding	128
	Messages.....	128
	Clearing stoppages.....	131
	Operator Troubleshooting.....	137
	Troubleshooting Table.....	138
11	Specifications	143
	Technical Specifications.....	143
	Hopper and Feeder Capacity.....	144
	Configuration Dimensions.....	144
	Document and Insert Specifications.....	145
	Envelope and Document Set Specifications.....	145
	maxiFeeder Specifications.....	147
	versaFeeder Specifications.....	148
12	Terminology	150
	Terminology.....	150

1 Read this First

Safety



Ensure you have read and fully understood the safety requirements in the [Safety Guide](#).

Declaration of Conformity (EU only)

The product presented in this guide meets the requirements of applicable directives. For more details refer to the Declaration of Conformity. Contact your authorized distributor for availability of this document.

About this manual

Disclaimer





This Guide is published without any warranty. Improvements and changes to the online Guide necessitated by typographical errors, inaccuracies of current information, or improvements to programs and/or equipment, may be made at any time and without notice. Such changes will, however, be incorporated into new editions of the PDF Guide (if applicable).

Download the PDF:



Symbols

This manual uses the symbols listed below.

This symbol...	Indicates...
	WARNING: Indicates a human safety hazard.
	ATTENTION: A risk to the equipment or mail could result from an action you may perform.
	NOTE: A remark that explains different cases or specificities.
	TIP: Advice to help save you time when processing your mail.
	SUPERVISOR: Indicates that you have to use the supervisor menu to perform the procedure.

Languages

In the EU the user guide must be available in the national language(s) of the country where the system is delivered. Therefore, if the User Guide is not available in your country's language(s), contact your authorized distributor.

Software

The software used for the reading option is based in part on the work of the Independent JPEG Group.

2 How this Help Works

Help Menu

The help button [?] gives access to help topics via a pull-down menu.

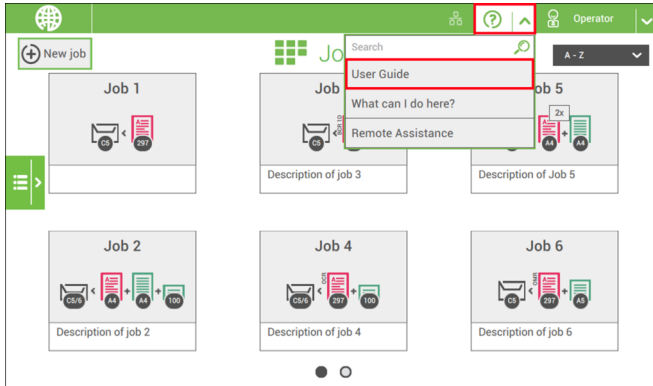

The contents of the help menu can be different for your situation. The help menu can contain the following topics:

- Search; use the search engine to find a specific topic.
- User Guide; user instructions describing how to use the system.
- FAQ's (option); when the system is connected to the internet, frequently asked questions are answered here (option).
- What can I do here; a list with relevant help topics related to the current screen.
- Remote assistance (option); online remote assistance for helpdesk guidance. Call the phone number that is displayed and follow the instructions of the support assistant.

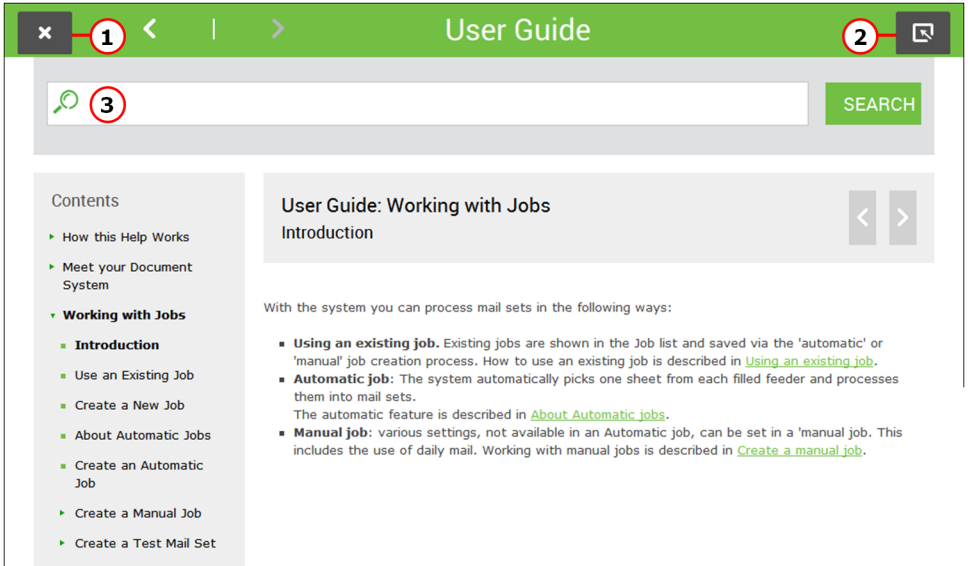

You can use this guide as follows:

1. Use the contents overview to browse the contents. When you are finished you can close the User Guide with the Close button.
2. To keep the topic from the User Guide active, you can use the Minimize button. When you click the active Help button, the User Guide is restored.
3. To search for topics; enter a keyword in the Searchbar and press the Search button.

To navigate through the User Guide:

- Tap to select.
- Swipe up/down to scroll.
- Double tap to zoom.
- Pinch in/out to zoom in/out.

See also [How to operate the touchscreen](#).

Remote Assistance (optional)



Ask your authorized distributor if this feature is available for your system/organization.



It is necessary that the system is connected to the internet.

(Online) Remote Assistance is a tool for help desk guidance. The Remote Assistance screen can be entered by tapping on the "Remote Assistance" button in the Help menu. Add the support key supplied by the support assistant and follow the instructions as indicated by the support assistant.

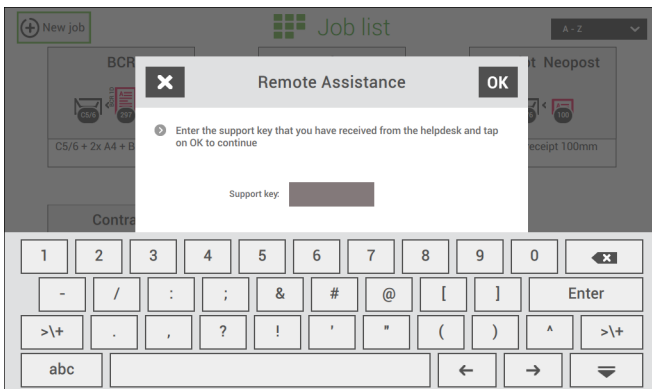
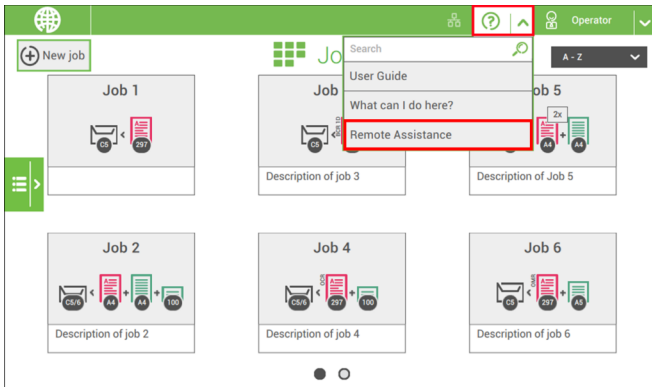

3 Meet your Document System

Introduction

The system is a folding and inserting system for processing mail easily. The system:

- feeds documents
- folds the documents
- inserts the documents into envelopes
- seals the envelopes
- stacks the envelopes

Automatic monitoring ensures the correct number of documents per envelope. The system can be operated by means of a user friendly interface. The settings of the system (type of documents, type of envelopes and the type of fold) are recorded in so called jobs. These jobs can be created by the operator.

Operator and supervisor

You can use the system as operator and as supervisor. The supervisor has access to more settings than the operator. You can switch from operator to supervisor in every screen. When you switch to supervisor, you see immediately the result: extra tabs appear for the advanced settings. Also the side menu contains extra functions.

System Overview

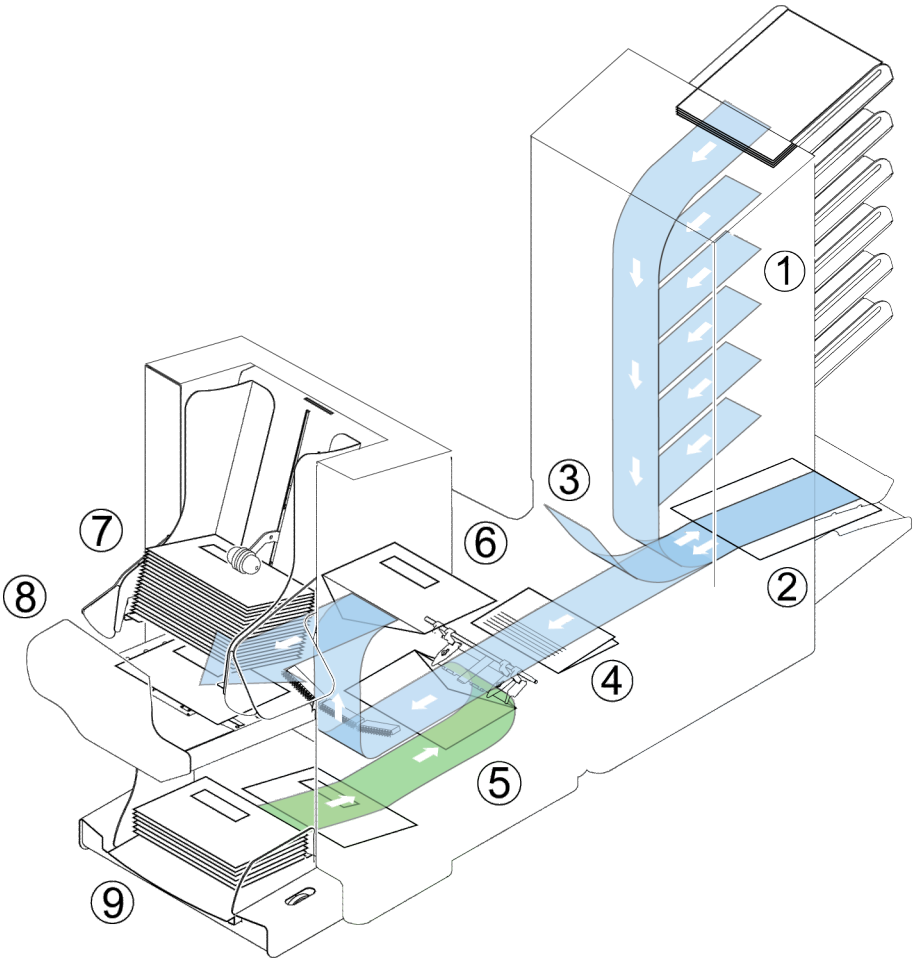

The figure shows an overview of the system.

Document Feeders (1)

The Feeder is the feeding part of the system. There are two types of feeders: the automatic and the special feeder. The automatic feeder does not require any adjustments for the separation. From a feeder you can feed one or more documents (multi feed). The feeders have a double feed control (DFC). DFC detects if more documents are fed instead of one.

You can link feeders. This means that two feeders can be linked as pairs. When the first feeder is empty, the system switches to the other feeder. Meanwhile the empty feeder can be refilled without stopping the system.

The upper automatic feeder is equipped with a 'daily mail' function. You can use this feeder to process sets of documents that you cannot process automatically (stapled documents and sets with varying thickness).

Collating Area (2)

All documents of a document set are collated and aligned in the collating area.

Divert Area (3)

The IntelliDeck automatically throws out incorrect sets of documents. In this way the system does not need to stop. Correct sets will be transported to the powerFold unit.

Folder Unit (4)

The fold unit folds the documents. The following fold types are possible (see [Terminology](#)):

- No fold
- V-fold
- C-fold
- Z-fold
- Double V-fold

Inserter (5)

After the documents are folded, the documents are transported to the inserter. The inserter inserts the documents into a waiting envelope. The inserter seals the envelope or not, depending on the settings. Automatic monitoring ensures the correct number of inserts per envelope.

Present on Deck (6)

The documents inserted (or not) can leave the inserter from the upper unit (present on deck). This can occur when:

- Clearing the machine;
- Making a test set;
- Depending on the reading code.

Stacker (7)

The documents inserted (or not) are transported to the stacker depending on the programmed job. The stacker automatically stacks inserted documents.

Side exit (8)

The documents inserted are transported to the side exit depending on the programmed job. The side exit can be used for sorting and stacking of documents into the catch tray as well as transporting to the optional conveyor belt or franking/mailing machine.

Envelope Hopper (9)

Envelopes that are placed on a stack by the user, are fed one by one into the system by the envelope hopper.

Operating Controls

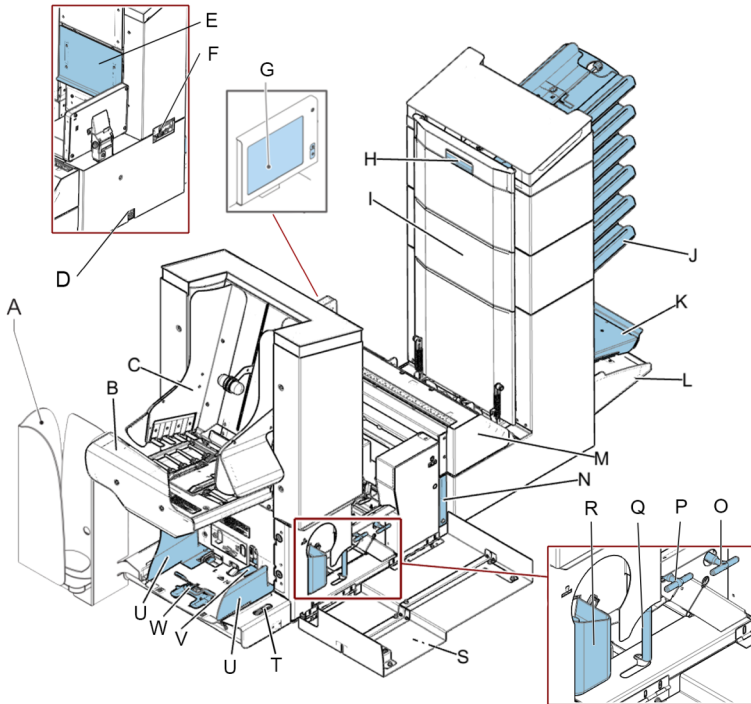

- A** - catch tray (optional)
 - B** - side exit / stacker unit
 - C** - side guides stacker
 - D** - power inlet, power switch
 - E** - unlocking lever for upper unit
 - F** - USB (2x), RS232 and ethernet
 - G** - control panel
 - H** - hand grip vertical transport cover
 - I** - vertical transport
 - J** - document feed tray
 - K** - collator arm
 - L** - divert area
 - M** - folder unit
 - N** - locking handle folder unit
 - O** - handle for manual transport of the envelope
 - P** - handle for manual transport of the mail set
 - Q** - unlocking handle for rollers envelope track
 - R** - sealing liquid reservoir
 - S** - side cover (opened)
 - T** - thumb wheel for side guide adjustment
 - U** - side guides envelope feed tray
 - V** - flap for envelope separation adjustment
 - W** - envelope support
-

Control Panel



On/Off (B): The touch sensitive button in the upper right corner of the display switches the system on or off. If the system is not used for one hour, the system switches off to safe power.

Status LED (C): A status LED indicates the state of the machine, a green LED indicates that the system is switched on, a blinking red LED indicates the system is switched off.



The display is a capacitive touch screen. To avoid permanent damage of the display, do not use sharp objects to operate the display.



To clean the display use a dry lint-free or microfiber cloth. If water is necessary to clean the screen, you should make your microfiber cloth slightly damp instead of putting the water directly on your screen. Never use large amounts of water, harsh chemicals, abrasive cloths or paper towels to clean the display.

How to Operate the Touch Screen

You can operate the touch screen like a tablet:

- **Tap** : touch and release the screen with your finger.
- **Swipe**: touch the screen, hold it and move your finger(s) left, right, up or down.
- **Tap and hold**: touch the screen with your finger and hold it for two seconds.
- **Pinch in/out**: to zoom in/out.

In some menus, when not all information is visible on the screen, it is possible to enlarge the view. Tap on a random white space position. The header and tab(s) will be hidden and the screen will “shift” upwards.

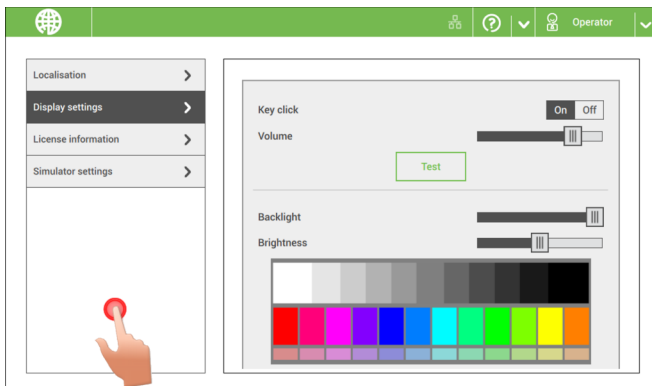

Tap again on a random white space position in order to return to normal view again.

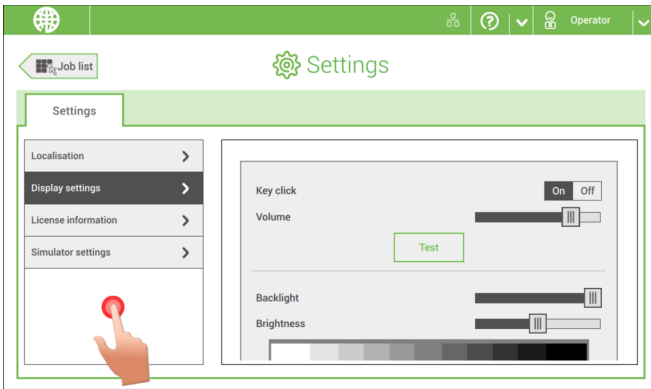

3

English

Use a Web Browser

You can open a web browser in the user interface of the system. Use the web browser as follows:

1. Tap on the icon in the upper left corner of the screen to open the Web browser.



2. You can tap or swipe to navigate through web sites.
Use the keyboard to type in the navigation bar of the browser or within web sites.



If you work with a special keyboard for your language, you can switch the keyboard back to the English version to type e.g. a web address. (see [Localisation](#) on page 84)

3. Tap the Minimize button to keep the Web Browser active.

4. Tap the Close button in the upper left corner of the screen to close the web browser.

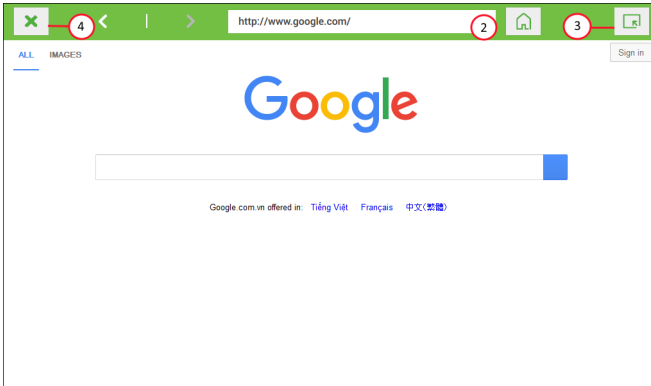

What is a Job?

If you have to process a lot of mail sets of the same type (for example bills), you can save the settings to a 'job'. The next time you just select the job and immediately start without defining any settings.

The following settings are saved in a job:

- Envelope type/size;
- Sealing on/off;
- Which document feeders should be used, how many documents should be fed from each feeder and document height for each feeder;
- Feeder linking on/off;
- If BREs or insert cards should be included;
- Address position;
- Fold settings;
- Double feed control settings;
- Reading settings (option);
- Exit select settings;
- Stop counter, also known as Batch counter, defining the number of mail sets that the job must process. The job will automatically stop processing when this number is reached.

Job List

3

English

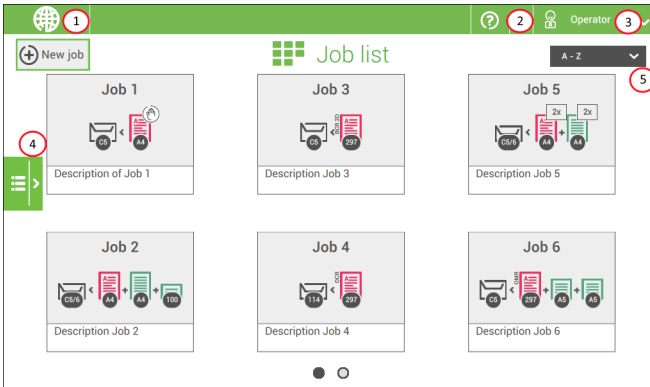

When you start up the system, the 'Job list' menu appears.

1. [Open a web browser](#) on page 12
2. [Help menu](#) on page 3
3. Login, see [Introduction](#) on page 6
4. Side menu
5. Job list sorting

The side menu contains the settings menu (see [Settings menu operator](#)). When you are logged in as supervisor, the settings menu is extended with advanced settings (see [Settings menu supervisor](#) on page 78).

If you want more information on a job, select the job. With the **[Job list]** button you get back to the home menu.

See also: [Working with Jobs](#) on page 25.

Job Overview

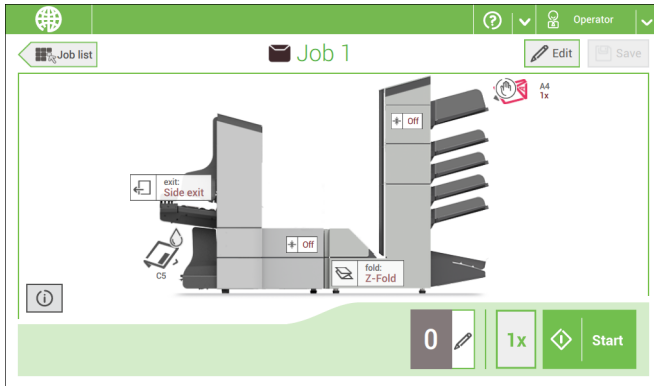

If you want more information on a job, select the job in the Job List menu.

The touch screen shows the following information of the selected job:

- Job name
- Job settings (for example the document and envelope type)
- How to load envelopes and documents for this job
- The number of envelopes that have been processed with this job







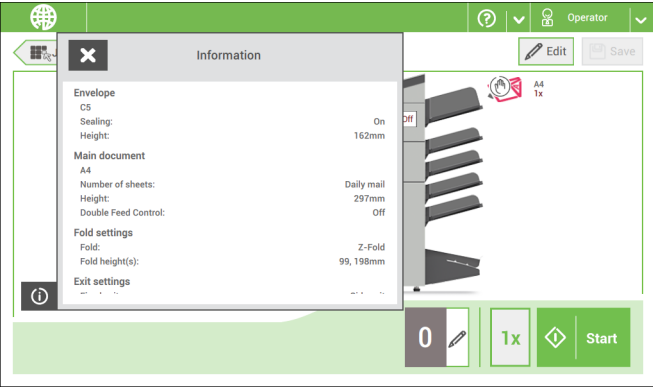







In this screen you can change the following settings:











- Counter settings (see [Change the counter settings](#))
- Job settings (see [Editing a job](#))
- Move documents between feeders (see [Change to an other feeder tray](#))
- Link feeders (see [Link feeder trays](#))
- Start the job or run a test run (see [Performing a test run](#))

If you tap the **[i]** button a summary of all information of the job is listed.



The following is a list of symbols or icons and their descriptions.

	<p>Main document. Shows the correct document orientation; A is the address.</p>		<p>Document with reading Shows the correct document orientation; A is the address.</p>
	<p>Daily mail Feature to manually insert mail-sets one by one into the system.</p>		<p>Enclosure</p>
	<p>Notification Next to this symbol, a message appears, e.g. Sealing liquid low, empty feeder.</p>		<p>Wired LAN connected Network connection is available via a network cable connection.</p>
	<p>Wireless LAN connected Network connection via Wi-Fi is available.</p>		<p>Wired LAN not connected Network connection is not available via a network cable connection.</p>
	<p>Wireless LAN connected, no internet Network connection via Wi-Fi is available, network is not connected to internet. Check with your network administrator.</p>		<p>Wireless LAN not connected Network connection via Wi-Fi is not connected or out of range.</p>
	<p>Envelope, sealing on Envelopes will be sealed. The symbol shows the correct envelope orientation.</p>		<p>Envelope sealing off Envelopes will not be sealed. The symbol shows the correct envelope orientation. When sealing is off, the flap of the envelope is closed but not moistened.</p>
	<p>Feeder linking Linking means that when one feeder is empty, the system automatically starts feeding documents from the other feeder. This symbol at the feeders shows if the feeders are linked.</p>		<p>Change feeder trays Possibility to change from one feeder tray to another.</p>

	<p>Dfc/mail set thickness detection Double feed control and/or mail set thickness detection has been set to 'off'. By default the dfc/mail set thickness detection will be set to 'on' and the icon will not be shown.</p>		<p>Fold type This icon shows what kind of fold type has been set.</p>
	<p>Exit setting This icon shows what kind of exit setting has been set.</p>		<p>Counter setting Shows on what number the counter has been set.</p>
	<p>1x button After tapping this button the system will create an example mail set.</p>		<p>Start button Tapping this button runs the job.</p>
	<p>Job list button After tapping this button the job list screen will be shown.</p>		<p>Stop button Button to stop the system The current mail set will be completed and the system stops, being empty and ready for a new set.</p>
	<p>Edit button Gives access for editing a job.</p>		<p>Save button Save the job or changes that have been made to a job.</p>

High Capacity Document Feeder (HCDF)



3

English

The High Capacity Document Feeder (HCDF) is an option that can be delivered from factory. The High Capacity Document Feeder has a capacity for up to 725 sheets. The normal document feeder tray has a capacity of 325 sheets.

For more information on the operation of the HCDF, refer to the topic on [loading documents for the HCDF](#) on page 68.

MaxiFeeder

3

English



The maxiFeeder is a feeder that can be loaded with a high number of documents. This feeder is intended to be used for Business Reply Envelopes (BRE), but also 'standard' documents up to 356 mm (14") length can be processed with it.

For more information on the operation of the maxiFeeder, refer to the topic on [loading documents for the maxiFeeder](#) on page 62.



A license is required if you want to use the maxiFeeder for documents larger than 156 mm (6.14").

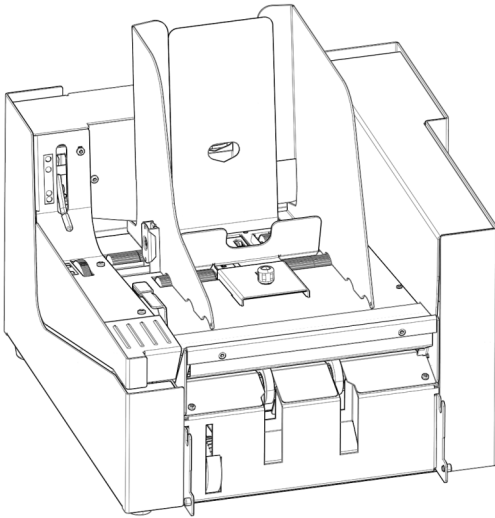

The versaFeeder is used to feed booklets, regardless of the thickness of the cover, to the document flow from the feeder to the inserter. Because of the location of the versaFeeder (downstream the feeder module) documents fed by the versaFeeder will not be folded.

When the versaFeeder is added to the configuration, this is shown in the screens at the operator panel.

For more information on the operation of the versaFeeder, refer to the topic on [loading documents for the versaFeeder](#).

Dual versaFeeder support

The system can support a maximum of two versaFeeders. Ask your local distributor for more information about upgrading this option.

High Capacity Conveyor Belt

The high capacity conveyor belt is designed for envelope transport from the inserter or franking device. The conveyor belt has two operation modes:

- The belt moves continuously.
- The belt moves in intervals. The belt moves about 45 mm (1.7 inch) each time a sensor detects the passage of an envelope.



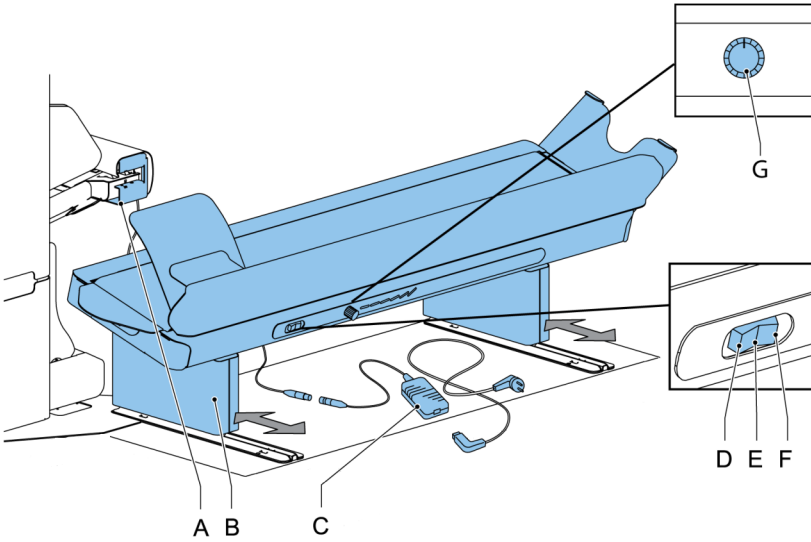

The guide plate and side guides prevent the envelopes from falling off the belt.

The conveyor belt switch has three positions:

- Mode **D**: the belt moves in intervals.
- Mode **E**: the belt is switched off.
- Mode **F**: the belt moves continuously.



With the turning knob (G) it is possible to set the interval distance between envelopes on the conveyor belt. The distance depends on the type of job and preference of the user.

(G)	Guideline:
	Minimal interval distance: 15 mm, setting for a job with thin envelopes. 
	Neutral interval distance: 20 mm
	Maximal interval distance: 40 mm, setting for a job with thick envelopes. 

Catch Tray for Side Exit



For stacking envelopes leaving from the side exit a catch tray can be mounted. You can select the catch tray in the Output settings tab of the job definition ([see Exit settings](#)).

Instead of a catch tray at the right hand (RH) side of the system it is also possible to install a catch tray on the left hand (LH) side. To achieve this it is necessary to reverse the side exit of the Stacker from RH to LH. Contact your supplier for more information about this option.

Power Stacker Support

Depending on the inserted type and amount of documents, the filled envelopes may get stack fanshaped at the stacker.

To prevent this, an optional power stacker support can be used in order to stack the envelopes correctly.

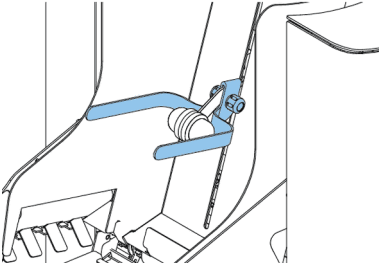

Automated Insertion Management System (AIMS)

The "Automated Insertion Management System", abbreviated as AIMS, is an optional software feature.

AIMS is a software system that monitors the progress of documents in real-time through a Document System (Folder-Insertor) providing various levels of reporting. In addition to reporting on the documents being processed by the Document System, it can also report on the performance of the system or systems processing the documents.

Contact your local distributor to find out if this feature is available for your organization.

Shut Down the System

1. Press the **[On/Off]** button to shut down the system.



In case the system is unresponsive or fails to switch off, press and hold the touch sensitive power button for 10 seconds to switch off the system.

When the system is busy, it completes and inserts the current set, stops and will be shut down.

4 Working with Jobs

Introduction

With the system you can process mail sets in the following ways:

- **Using an existing job.** Existing jobs are shown in the Job list and saved via the 'automatic' or 'manual' job creation process. How to use an existing job is described in [Using an existing job](#) on page 25.
- **Automatic job:** The system automatically picks one sheet from each filled feeder and processes them into mail sets. The automatic feature is described in [About Automatic jobs](#) on page 27.
- **Manual job:** various settings, not available in an Automatic job, can be set in a 'manual job. This includes the use of daily mail. Working with manual jobs is described in [Create a manual job](#) on page 28.

4

English

Use an Existing Job

If you want to use an existing job:

1. Open the job list.
2. Tap the icon of the job you want to use.

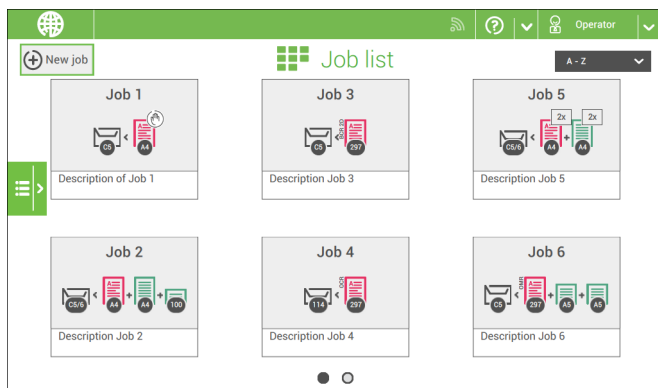

3. Load the feeders as shown on the display.
4. Tap **[1x]** to create an example mail set, see [Example mail set](#).
5. Select an exit for the example mail set.
6. Check the example mail set.

- If example mail set is OK: tap **[Start]**.

If the example mail set is not OK: adjust the address position or envelope stop position or check and re-adjust the job settings.



If desired tap the counter button to set the counters. See [Counter settings](#).

- Tap **[Start]** to start the job.
- Press the **[Stop]** button to finish the job.
- Tap **[Job list]** to return to the job list.

Create a New Job

To create a new job:

- From the Job list menu, tap **[New job]**.
- Choose **[Automatic]** or **[Manual]** to create a new job.

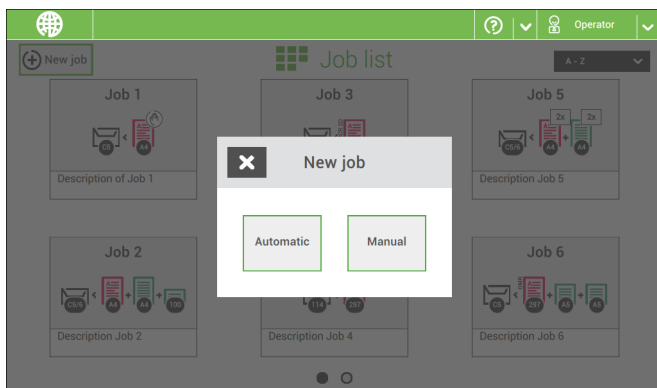

- If you choose 'Automatic' follow the description as can be found in [Create an Automatic job](#).
- If you choose 'manual' follow the description as can be found in [Create a Manual job](#).

About Automatic Jobs

You can save every automatically created job and edit it like any job.

An Automatic job processes mail sets according to the following rules:

- The machine picks one sheet from each filled feeder;
- The picked documents will be folded (if necessary) and inserted into an envelope;
- Only the feeders that feed successfully will be selected;
- Only the Double Feed Control (DFC) of the upper feeder will be selected (this is done automatically).

The following features are not supported with Automatic job processing.

- Linked feeders (the option where, if one feeder is empty, the system automatically continues using another feeder)
- Multiple sheet feeding (picking more than one sheet from a certain feeder)
- Daily mail
- Reading functionality
- No envelopes (use envelopes yes/no)
- Exit select

If you want to use any of these features, you have to use Manual jobs to process the mail set.

Create an Automatic Job

Proceed as follows if you want to create an automatic job:

1. From the Job list menu, tap **[New job]**.
2. Tap **[Automatic]** to start an Automatic job.

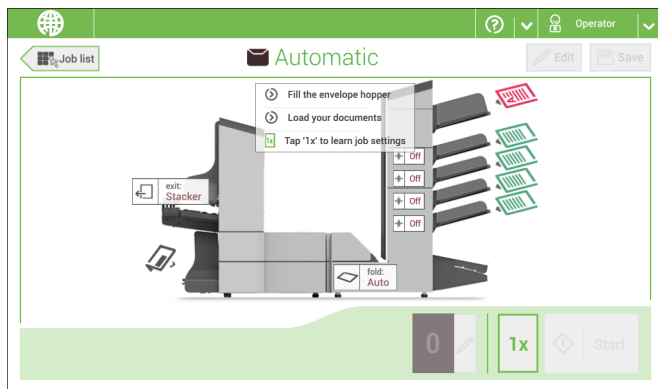

3. Fill the envelope hopper, load your documents and tap **[1x]** to create an example mail set.

4. Make sure that the address position and the envelope stop position is correct. If not, [adjust the address position](#) and [envelope stop position](#).
5. If necessary, tap the counter symbol to set the counters. See [counter settings](#).
6. Tap **[Start]** to start the job.
7. Tap **[Stop]** to finish the job.

Tap **[Save]** if you want to save the settings of the Automatic job to a new job.

Create a Manual Job

Introduction

Creating jobs manually is easy: the user interface guides you through the job definition with clear steps.

These steps are:

- Define the mail set: envelope type, main document and optional enclosures.
- Define how to fold the document set.
- Define the exit of the system that should be used for this job.

Create a Manual Job

To create a job manually:

1. From the Job list menu, tap **[New job]**.
2. Choose **[Manual]** to define the job settings.

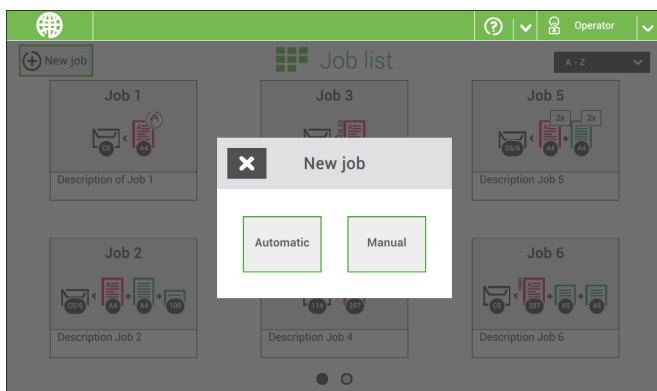

Continue with the envelope settings (see [Envelope](#)).

Mail Settings

Envelope

1. Tap **[Envelope]**.

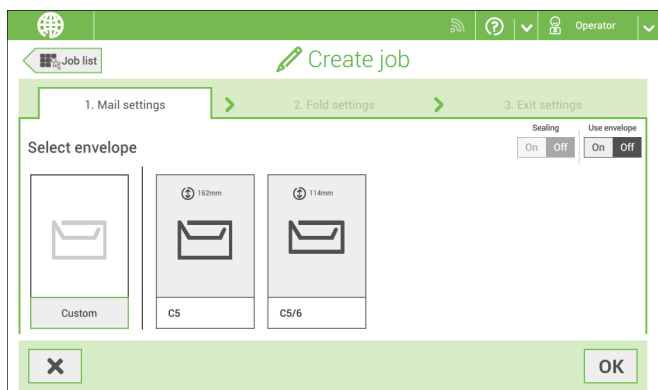

2. Select a predefined envelope or [create a custom envelope](#).

Optionally tap **[Use envelope]** to set the use of envelopes to 'off' if you want to Create a job without the use of envelopes.

3. Tap **[Sealing]** to switch it on or off.



By default the envelopes will be sealed.

4. Confirm the envelope settings with **[OK]**.

Continue with the main document settings.

Main document

4

English

1. Tap **[Main document]**.

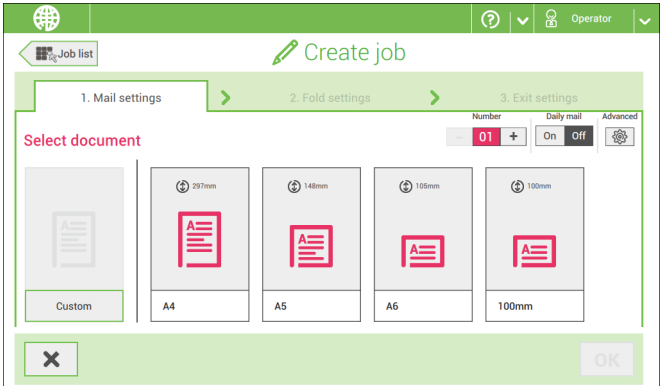

2. Select a predefined document or [create a custom document](#).
3. Change the **[Number]** to add more than one document from a feeder (multiple sheet feeding).
4. Optionally tap **Daily Mail** to set Daily Mail to 'on' or tap **[Advanced]** to set the [DFC Settings](#).
5. Confirm the document settings with **[OK]**.

Continue with the enclosure settings.

Switch DFC on or off for feeders

For every feeder you can switch the double feed control (DFC) on or off.

To change the DFC settings:

1. Tap the job that you want the change the DFC settings for.
2. Tap **[Edit]**.
3. Tap the document that you want to change the DFC for.

4. Tap **[Advanced]**.

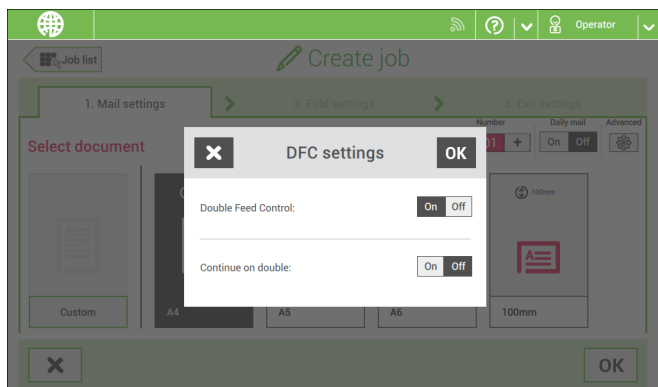

5. Tap Double Feed Control to switch it on or off.
6. Tap Continue on double to switch it on or off. If Continue on double is on, the machine will not stop if two sheets are fed instead of one. The document-set that contains the double sheets will be diverted.
7. Confirm the settings with **[OK]** and continue with the document settings.

Enclosure

1. Tap **[Add enclosure]**.

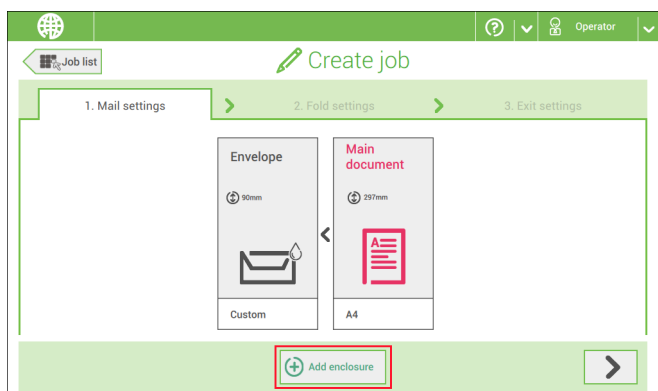

2. Select a predefined document or [create a custom document](#) as your enclosure.
If you want to remove an enclosure from the job, or change the order of the enclosures, see [Delete or move an enclosure](#).
3. Change the **[Number]** for more than one document from a feeder.

4. Confirm the enclosure settings with **[OK]**.

Continue with the fold settings (see [Fold settings](#)).

Fold Settings

Default the machine suggests the most logical fold type. This fold type is highlighted. However, you can select other fold types and change their settings.

1. Tap a fold type.

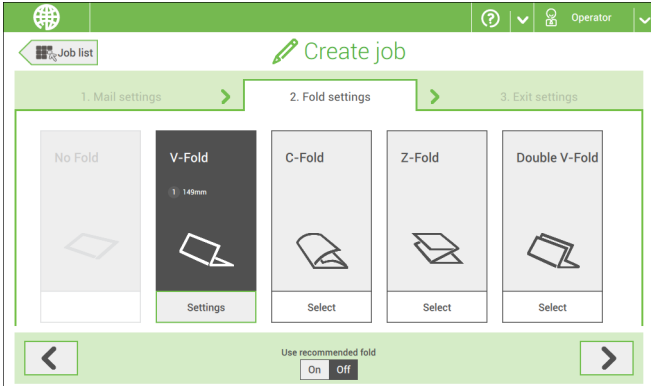

2. If necessary, tap **[Settings]** to change the fold settings.
3. Tap **[>]**.

If you want to revert to the machine recommended fold type, switch **[Use recommended fold]** to On.

Continue with the exit settings (see [Exit settings](#)).

Exit Settings

1. In Exit Settings the Fixed exit is selected by default.

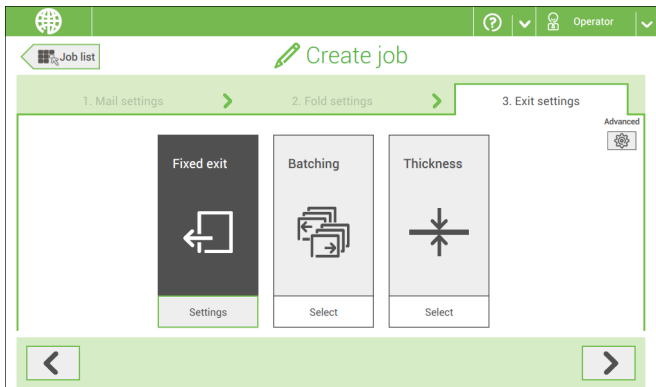

2. Optionally tap the **[Advanced]** button to set the Advanced settings per job.
3. Tap **[>]**.

Continue with [Finish the job definition and start the job](#), or set the [counter settings](#).

Switch the mail set thickness detection on and off

You can switch the mail set thickness detection to 'yes' (= on) or 'no' (= off). By default the mail set thickness detection is set to 'yes'.

To change these settings:

1. Select the job that you want the change the mail set thickness detection setting for.



If the job uses reading, you cannot switch on the Mail Set Thickness Detection (DFC) for the document set. With reading, the document set size can be different for every set.

2. Tap **[Edit]**.
3. Navigate to Exit settings.

4. Tap [Advanced].

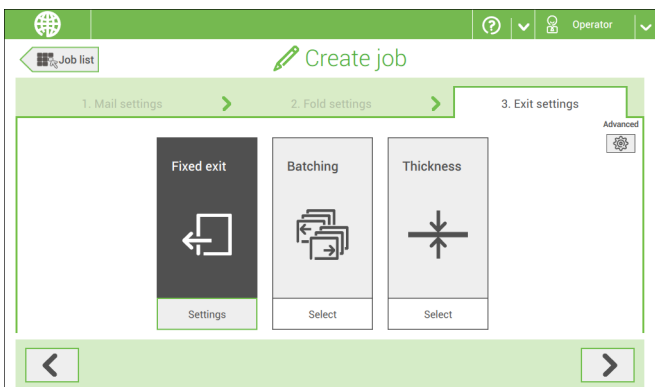

5. Tap the 'Double Feed Control' button to switch it on or off.

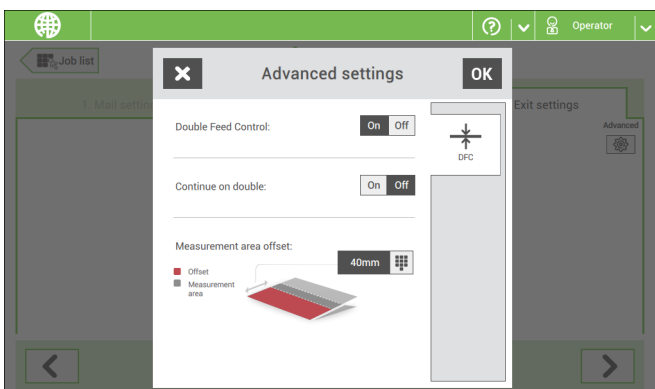

6. Tap the 'Continue on double' button to switch it on or off.

If Continue on double is on, the machine will not stop if two sheets are fed instead of one. The mail set that contains the double sheets will be presented on deck.

7. Enter the 'Measurement area offset'.

After the DFC detects the document set, it delays the thickness measurement. It starts measuring as soon as the offset has passed.

Job Settings (per job)

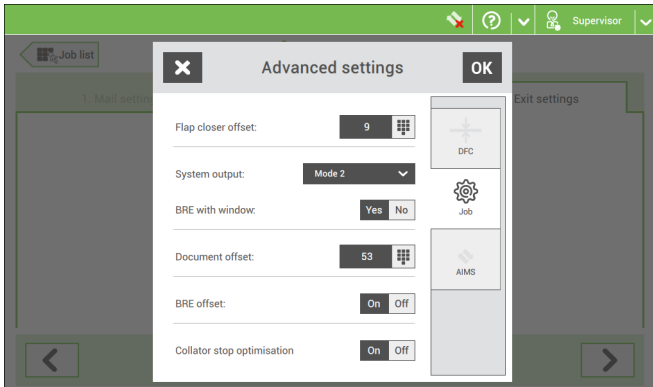

The Job settings part of the "Advanced settings" menu covers settings that improve the processing of jobs:

- **Flap closer offset:** to improve the sealing of specific envelopes you can delay or advance the moment of sealing. You enter the number of pulses. A minus value means the sealing is advanced, a plus value means the sealing is delayed. You can enter a number between -20 and 20.
- **System output:** mode 1 mode 2
Mode 1 focuses on the versatility of paper parameters (paper thickness; document length), i.e. correct operation under even extreme paper conditions. Mode 2 is the default mode, and focuses on high speed. Use Mode 1 with a paper thickness of 65 g/m² or less, a document length of 12 inch (305 mm) or higher, and for situations where Mode 2 is not functioning properly. In all other cases use Mode 2.
- **BRE with window:** if the BRE has a window, set this setting to yes. Only available with Mode 2.
- **Document offset** (A in the figure): the extend to which documents are not overlapping in the vertical transport. In the vertical transport of documents fed by the various feeders, the documents are partially overlapping each other. This to make sure that the documents are properly aligned in the collator area. The default value is 50 mm (2.0 inch). The document offset can be varied between 20 mm (0.8 inch) and 250 mm (9.8 inch).

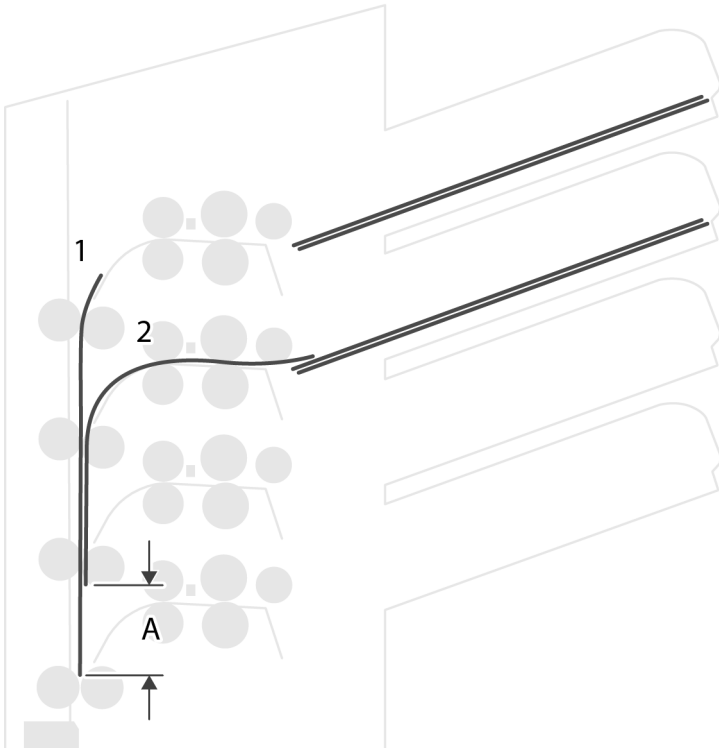

- **BRE offset:** in the case of offset is "yes", the last document that was added to the set is shifted from the rest of the set (offsetting, see below).
- **Collator stop optimization:** if set to "off", the system does not show a message, when a collator stop change can improve the system output.

Explanation of BRE offset: if a BRE is longer than the set fold but shorter than the envelope height, this BRE can get folded (A in the figure). Under certain conditions (see below) you can prevent the BRE from being folded. In the case of offset "yes", the BRE is held back during a certain distance (B in the figure). This means that the trailing edge of the BRE leaves the collator last. The document is not folded. During the insertion into the envelope the documents of the set are aligned.

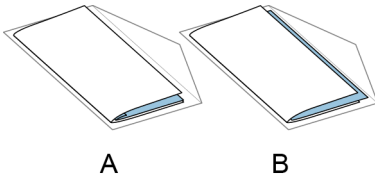

A

B

The conditions are:

- No multi-feed is used for the BREs.
- The document directly under the BRE must have a height of at least 60 mm (2.4 inch) more than the BRE.
- The height of the BRE is more than the set fold length.
- The folding mode is either V-fold or C-fold (no Z-fold).
- The BRE must be shorter than the envelope height.

The whole BRE offset is based on friction between documents within a set. Therefore it is necessary to make use of these conditions to reduce the risk of bad transporting, folding and inserting.



It is possible to use the BRE offset for a BRE and an enclosure (card) in one set. The extra condition is that this enclosure is equal to or smaller than the set address fold and should be placed direct underneath the BRE in the set.

AIMS settings

In case AIMS Mailpiece Id and Job Id is used in a barcode definition, the "Verification" mode can be enabled. When set to "Verification" all mail pieces will be verified with the AIMS server.

When switched to Off, the job will run normally but the mail pieces will not be verified with the AIMS server.

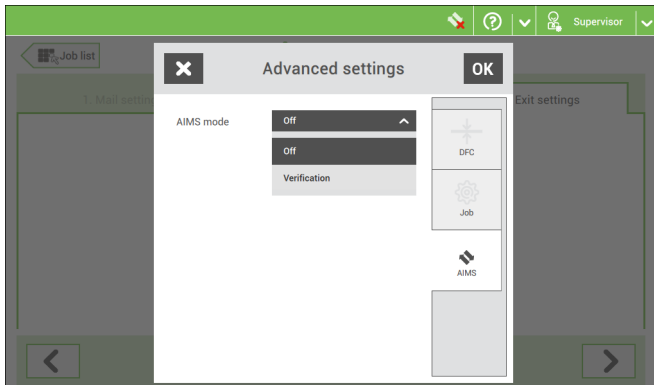

Change the Counter Settings



The counter settings are job related.

4

English

In the Counter submenu you can set the (daily) Job counter, the Stop counter and the Job total counter. The following will be shown in the Counter submenu:

- Job counter (as shown), the daily job counter: number of mail sets that have been processed using this job, after tapping [Start].
- Stop counter/Stop at value: set a number (of processed mail sets) after which the system stops processing. You can set from 5 through 9999. The system will continue processing mail sets until the job counter reaches the stop counter value. The system stops and can be restarted.

When the processing of mail sets has been interrupted the system shows how many mail sets have been completed. This is shown at 'completed so far'.

- Job total counter: total number of mail sets that have been processed using this job.

To reset/set the counters proceed as follows:

1. In the Job overview screen tap the counters button.

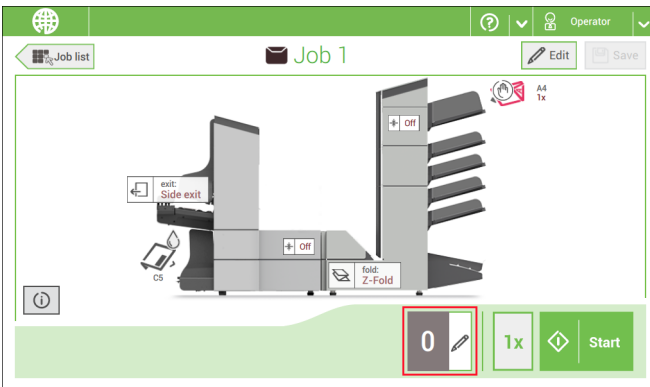

2. Tap the reset button for the daily job counter to set it to zero.

3. Tap the **[on/off]** button to set the Stop counter to 'on' or 'off'.

If you set the Stop counter to 'on' you can enter the 'Stop at value'. Enter a value from 5 through 9999.



Be aware that when the system stops based on the stop counter, there can still be documents in the system. To clear the system from documents, remove the documents from the feeder trays and tap [Start] from the warning message; the remaining documents will be processed to clear the system.

4. Tap the reset button for the Job total counter to set it to zero.



If you set the Job total counter to zero the number history of this job will be lost.

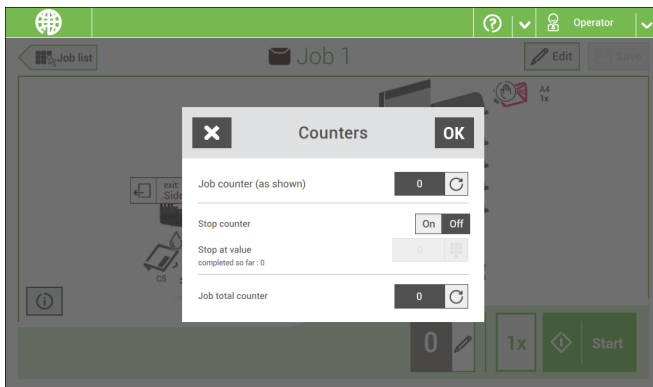

5. Tap **[OK]** to go back to the job overview screen and tap **[Start]**.

Finish the Job Definition and Start the Job

When you have finished the exit settings, the touch screen shows an overview of the job settings.

In this screen you can change the following settings:

- Move documents between feeders (see [Change to an other feeder tray](#))
- Link feeders (see [Link feeder trays](#))
- Change the counter settings (see [Change the counter settings](#))

When you are ready with these settings, proceed as follows:

1. [Load the documents](#) on page 57 as indicated on the Job info screen.

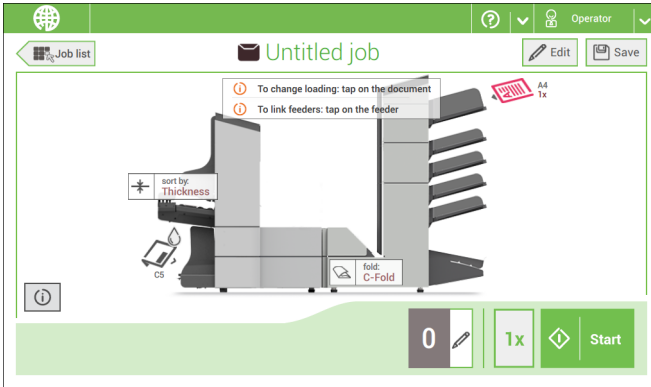

2. Tap [**1x**] to create a test mail set (see [Test mail set](#)).
3. If desired, you can save the job (see [Save a job](#)).
4. Tap [**Start**] to start the job.

Create a test mail set

Create a Test Mail Set

Before starting an existing job or a new, manual created job, it is possible to create a test mail set.

This test run is intended to validate the settings of the Inserting System:

- Check if the address is correctly positioned behind the envelope window. See [Adjusting the Address position](#).
- Inspect and adjust the stop position of the envelope. See [Adjusting the Envelope Insert fingers](#).
- Check the fold settings for one set. See [Fold settings](#).

When you tap the **[1x]** button, you can choose between test mail sets:

- Selected exit: creates one mail set that leaves the system at the defined exit. Use this option to test the complete process.
- Envelope stop position: separates one envelope and transports the envelope to the envelope stop position. Use this option to verify and adjust the envelope stop position.

After a test mail set, the system asks if the mail set is ok or not ok. When you select not ok, you are guided through a wizard that helps you to find the cause.

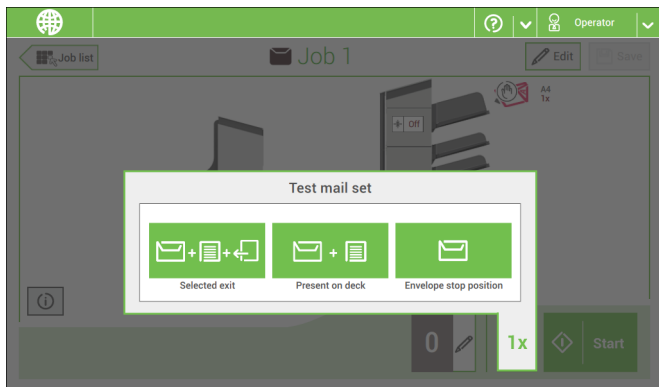

Verify the Insert Position



This adjustment must only be checked in case of problems or when changing the envelope type.

To verify the insert position:

1. Choose a job and tap **[1x]** (envelope only).
2. Lift the unlocking lever A of the upper unit and pull up the upper unit.

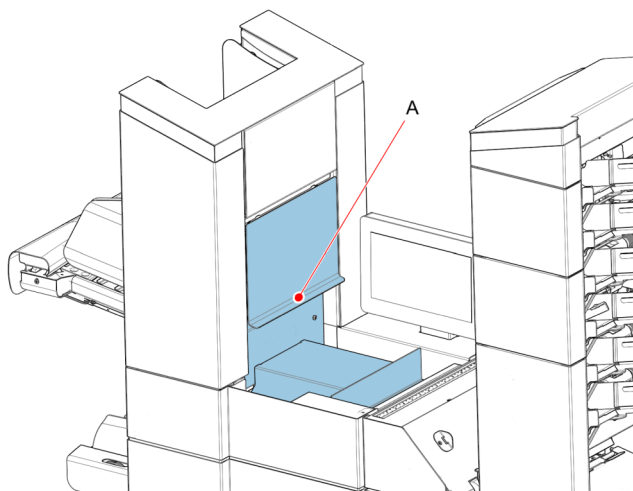

3. Follow the instructions on screen.

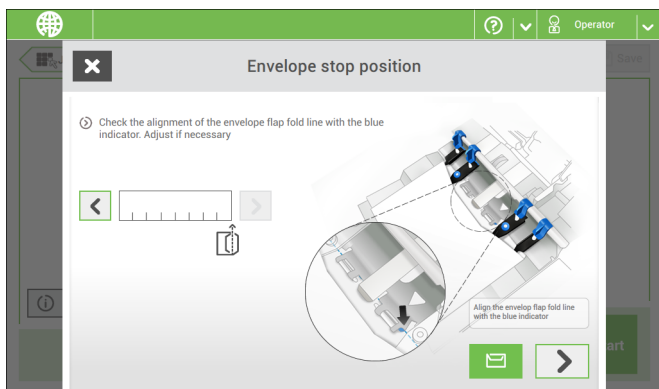

4. Tap the envelope button to fetch another envelope.
5. Make sure that the insert position is correct. If not, repeat the steps for adjusting the insert position.

Adjust the Envelope Insert Fingers

To verify that the position of the fingers is correct:

1. Choose a job and tab **[1x]** (envelope only).

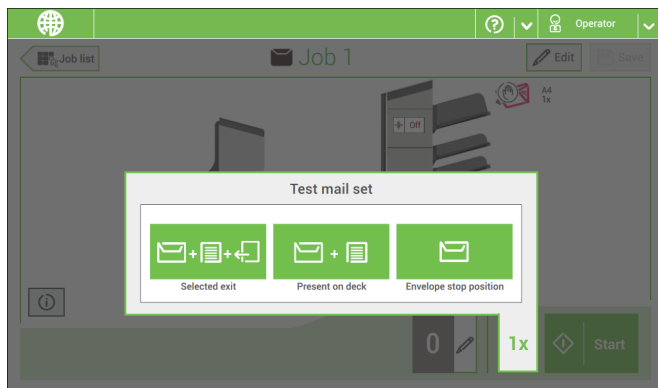

2. Tap the 'Envelope stop position' button.
3. Lift the unlocking lever A of the upper unit and pull up the upper unit.

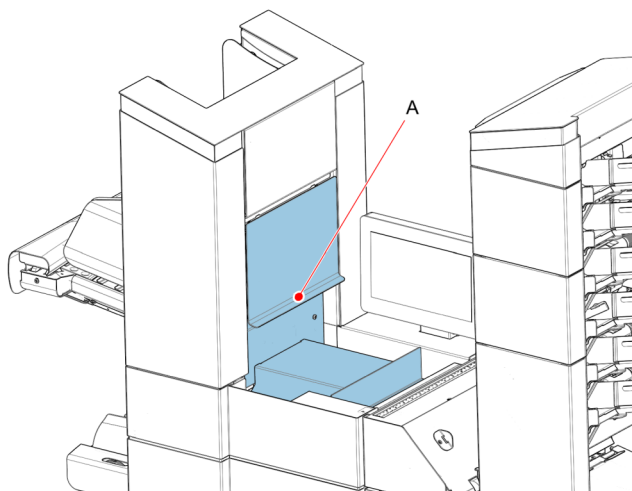

4. Tap the arrow to move to the next screen.

5. Follow the instructions on screen.

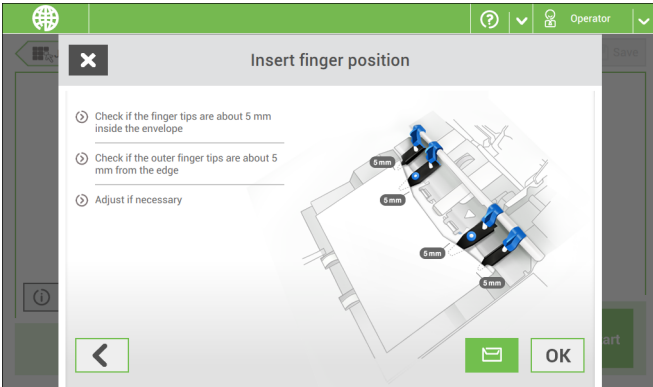

If the insert fingers are not correct, adjust the fingers as follows:

1. Loosen the knurled knob **C** on top of each finger.

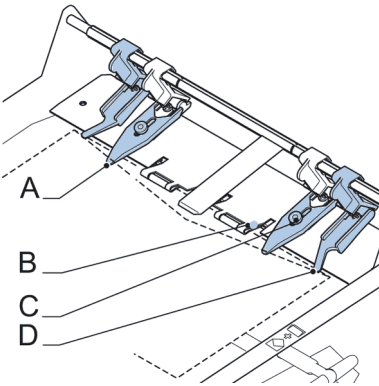

2. Adjust each finger so that the tip enters about 5 mm (0.2 inch) into the envelope.

3. Re-tighten the knurled knob.

The fingers can be moved sideways to the desired position.

4. Place the outer fingers **D** about 5 to 10 mm (0.2 to 0.4 inch) from the edges of the envelope.



Check the position of the insert fingers when changing to a different type of envelope.

5. Tap the envelope button on the touch screen to fetch another envelope.

6. Make sure that the finger position is correct. If not, repeat the steps for adjusting the fingers.

Adjust the Address Position



Adjusting the address position is only possible after creating an example mail set (by using the **[1x]** button).

If the address on your mail is not correctly positioned behind the envelope window, change the address position as follows:

1. Choose a job and tap **[1x]**.
2. Tap **Mail set not OK** if asked if the mail set is correct.
3. Tap **Address position not correct**.
4. Change the address position: slide the position indicator to the correct position.

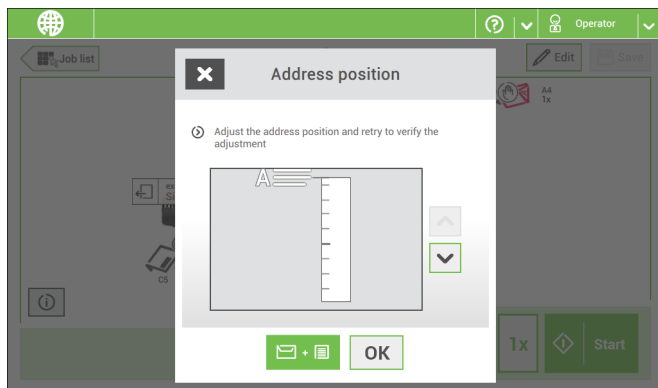

5. Tap the green button to create another example mail set or tap **[OK]** to confirm the settings.

Adjust the Separation of Special Feeders



Adjust the separation of special feeders as follows:

1. Push knob **A** forward until it clicks.

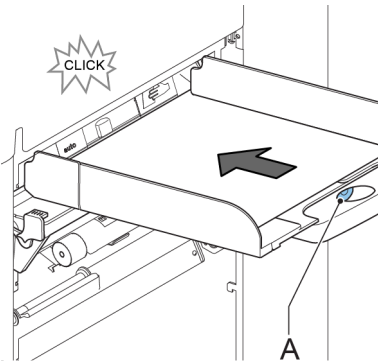

2. Turn knob **A** counter clockwise to open the separation gap.
3. Place a document on the feeder tray and slide it into the system until it can go no further.
4. Turn knob **A** clockwise to get resistance.
5. Move the document to and fro. The separation is adjusted correctly when a slight resistance is felt on the document. Turn knob **A** counter clockwise again if the resistance was set too high.

- Pull the knob **A** back again when ready.

Process a Mail Set with BRE or Inserts

A mail set with BRE or insert consists of a main document (address carrier), a BRE or an insert and perhaps other enclosures. This set is inserted into an envelope.

- From the Job list menu, tap **[New job]**.
- Add the BRE as a (custom) enclosure.
- Follow the job creation process (see [Create a manual job](#) on page 28).

Process Mail Sets with Daily Mail

To process mail sets with Daily Mail:

- [Create a Manual job](#) and select **[DailyMail]** for your Main document.

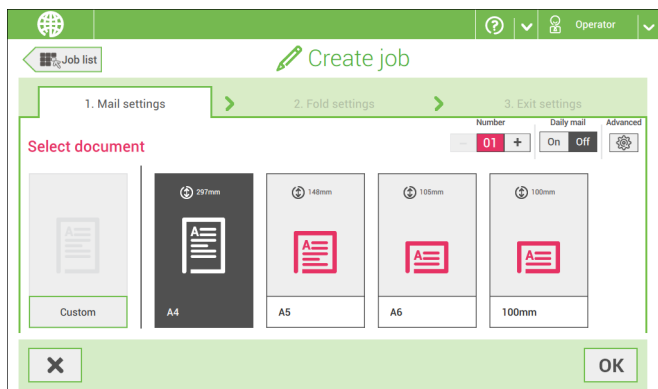

- Complete the job settings.
- Tap **[start]** to start the job.

A daily mail switch notification and instruction appears on the screen.

4. Turn down the left side guide **A** of the upper tray (not applicable when using a High Capacity Document Feeder). Now you can see the Daily Mail handle **B**.

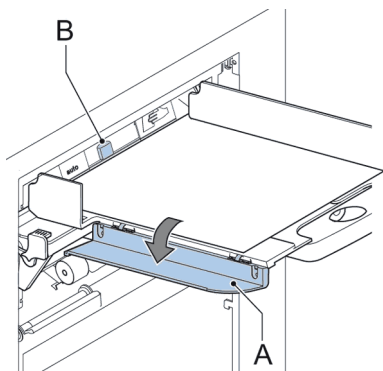

5. Move the handle **B** to the right to enable the Daily Mail function.
6. Turn side guide **A** upwards.
7. Place the document or document set in the feeder tray.
The document or document set will be folded and inserted into the envelope as described in the selected job.
8. Place the next document or document set in the feeder tray. The system will keep running to process the inserted document or document set.
9. When finished with Daily Mail, tap **[stop]** to stop the job.
10. Set the Daily Mail handle **B** to the 'AUTO' position to disable the Daily Mail and enable the automatic document separation.

Create a Job with Custom Envelopes



Makes sure that your custom envelopes fit within the specifications (see [Envelope Specifications](#) on page 145).

1. [Create a Manual job](#) and select envelope.
2. Tap **[Custom]**.

3. Enter the envelope height.

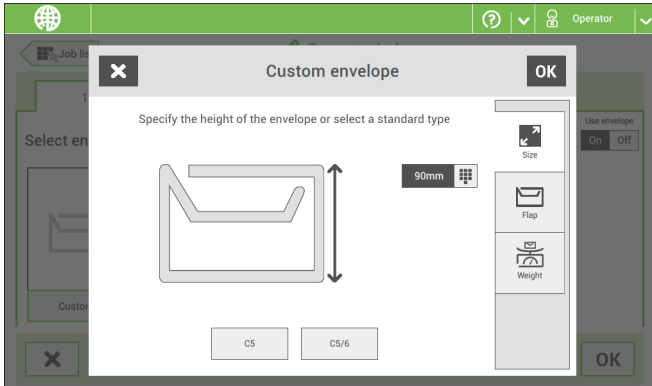

4. Tap the **[Flap]** tab if you use open flap envelopes.
5. Select if you want to feed envelopes with flaps up (On) or with flap down (Off).
6. Tap **[OK]** to save and close the envelope settings.
7. Complete the Fold Settings and Exit Settings to complete the job and tap **[Save]** to save the job.

Follow the instructions as described in '[Create test mail set](#)'.

Create a Job with Custom Documents



Makes sure that your custom documents fit within the specifications (see [Document Specifications](#) on page 145).

1. [Create a Manual job](#) and select a custom document as your main document or enclosure.
2. Tap **[Custom]** to create a custom document.

3. Enter the height of the document.

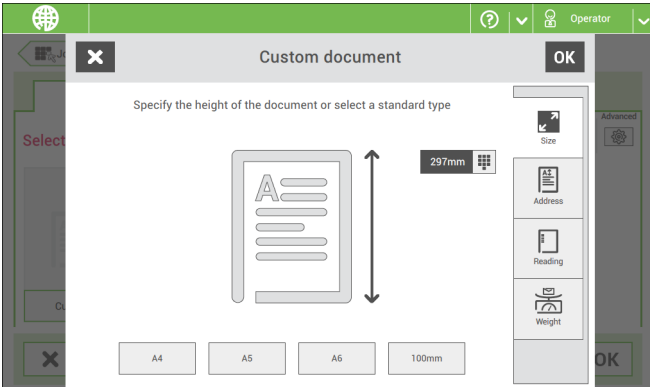

4. Confirm the document settings with **[OK]**.
5. Complete the Fold Settings and Exit Settings to complete the job and tap **[Save]** to save the job.

Follow the instructions as described in '[Create a test mail set](#)'.

Change to Another Feeder Tray



You cannot change the order of the documents in the mail set by changing feeders. If you want to change the order of the mail set, see [Delete or move an enclosure](#).

If you want to move the main document or enclosures to another feeder tray:

1. Select a job from the Job list.
2. Tap the document that you want to move to another feeder tray.

All available feeder trays are marked with a dotted box.

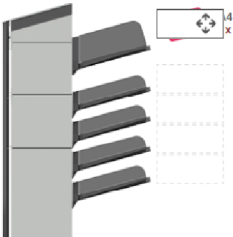

3. Tap the dotted box of the feeder tray where you want to move your document to.
The new feeder tray is selected for feeding of the document.
 4. Tap **[Save]** to save the feeder tray selection to the job.
-

Link Feeder Trays

Link feeder trays as follows:

1. Select a job from the Job list.
2. Tap the feeder tray that you want to link to another feeder tray.

The link symbol appears.

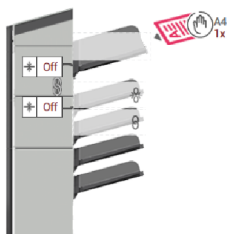

3. Tap the link symbol.
The figure shows an example of linked feeders.
4. Tap **[Save]** to save the link to the job.

When you want to un-link the feeders, tap the feeder trays and tap the un-link symbol.

Edit a Job

To edit an existing job:

1. From the Job list menu, select a job you want to edit.

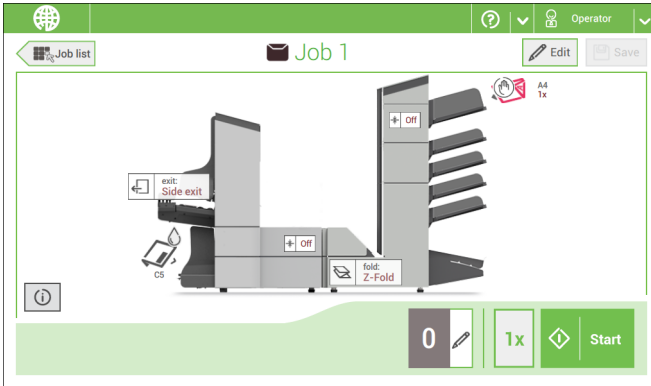

2. Tap [Edit].

When you tap **[Edit]**, you enter the guided job flow that enables you to make the desired changes.

3. Make the changes you want to make. When you completed the job programming, tap [Save] to save the changes.

4. Tap [1x] to make sure that the Insert Position and Address Position are correct (see [Verifying the Insert Position](#) and [Adjusting the Address Position](#)).

Save a Job

When you have created a new job or edited a job, save the job as follows:

1. After you have completed the job definition, tap **[Save]**.
2. Enter the job name.
3. If necessary, add a description to the job. The description is visible in the job list.

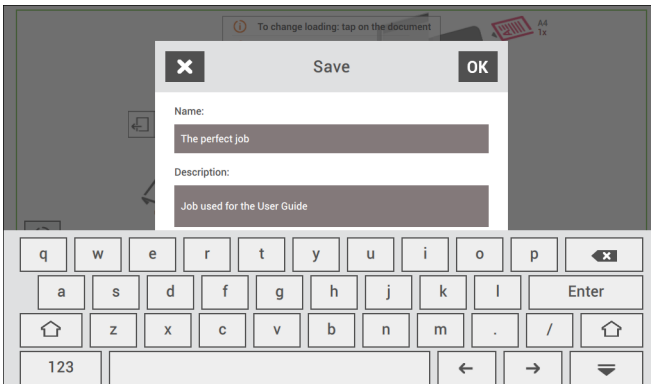

4. Tap **[OK]** to save the job.

The job is added to the job list.

Delete or Move an Enclosure

If you want to delete an enclosure in your job or change the order of the enclosures, proceed as follows:

1. From the Job list menu, select a job you want to edit.
2. Tap **[Edit]**.
3. Tap and hold the enclosure you want to move or delete.

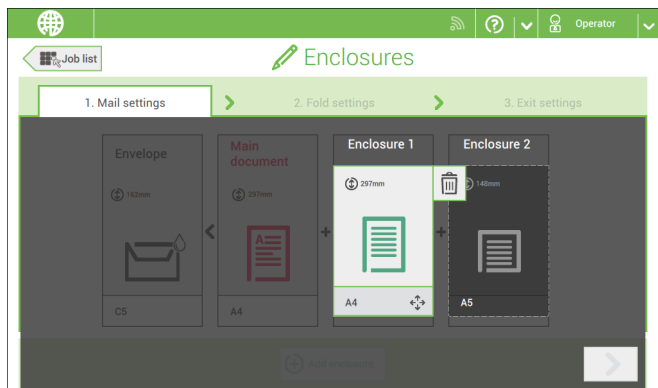

Now drag the enclosure to an other position. Or tap the waste bin to delete the enclosure from your mail set.

4. Tap the arrow buttons [**>**] to pass the other job definition steps and close the job editor.
 5. Tap **[Save]** to save the changes.
 6. Tap **[1x]** to make sure that the Insert Position and Address Position are correct (see [Verifying the Insert Position](#) and [Adjusting the Address Position](#)).
-

Copy a Job

To copy existing job settings to a new job:

1. Tap and hold the job in the Job list menu.

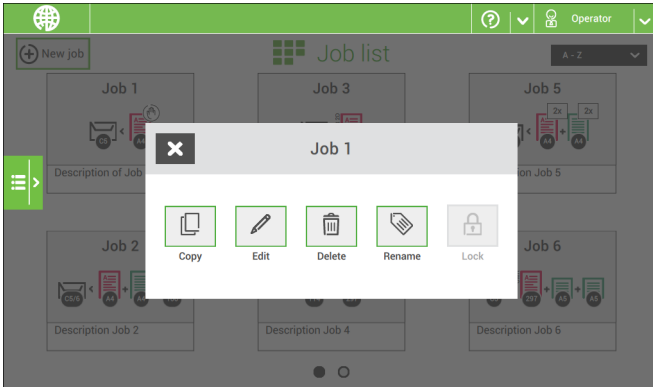

2. Tap **[Copy]**.
3. Enter the name of the new job and tap **[OK]**.

Delete a Job

To delete an existing job:

1. Tap and hold the job in the Job list menu.

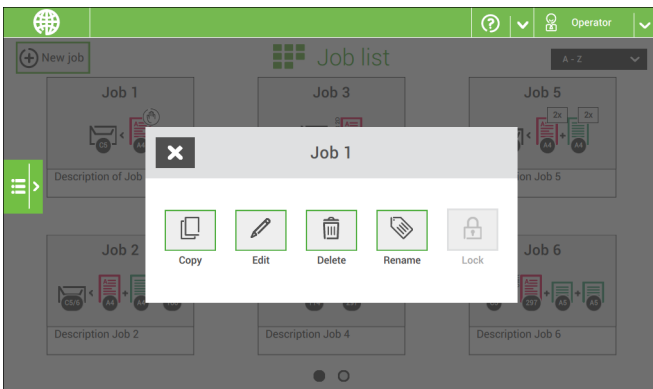

2. Tap **[Delete]**.

3. Tap **[OK]** to confirm.
-

Rename a Job

To rename a job:

1. Tap and hold the job in the Job list menu.

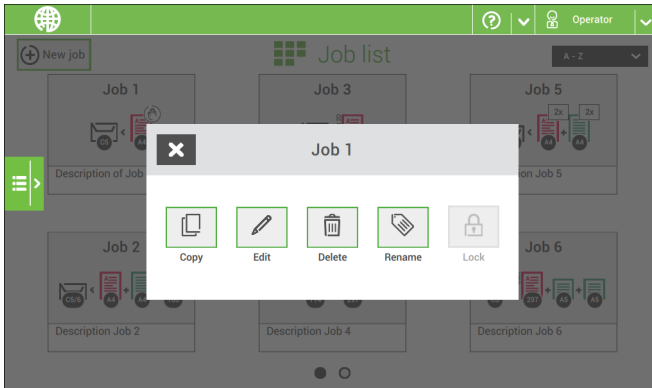

2. Tap **[Rename]**.
 3. Enter the name of the new job and tap **[OK]**.
-

Lock a Job

To lock an existing job:

1. Log on as supervisor.
2. Tap and hold the job in the Job list menu.

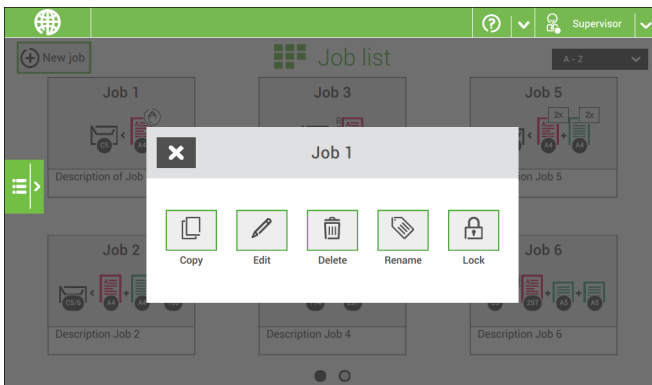





3. Tap [**Lock**].
4. Tap [**OK**] to confirm.

The job shows a lock in the job list. If the supervisor is logged on, the lock is open. If the operator is logged on, the lock is closed. The operator cannot edit, delete or rename the job, when the job is locked.

5 Loading the System

Document Orientation

The touch screen shows how to load documents and envelopes into the feeders. The table shows the meaning of the symbols:

	Address carrier face up and leading (top address)
	Address carrier face up and leading (bottom address)
	Address carrier face down and trailing (top address)
	Enclosure face up
	Enclosure face down

Document Feed Trays

Install the Document Feed Trays



Place the document feeder trays in position:

1. Hold the document feeder tray slightly inclined as shown in the figure.

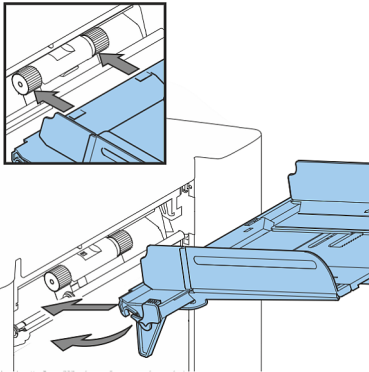

2. Place the front end of the document feeder tray underneath the two black rollers.

5

English

3. Move the document feeder tray upwards (lifting the black rollers), until it is possible to 'hook' the feeder tray into place.

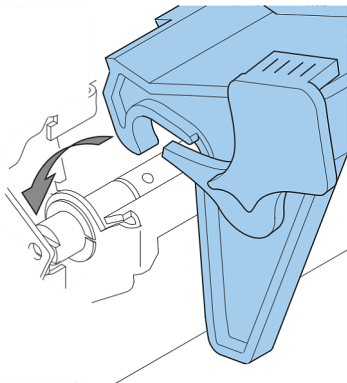

4. Move the document feeder tray towards the machine and move the hooks over the mounting points (on both sides).
5. Let the document feeder tray rest on the machine.

Adjust the Side Guides



To adjust the side guides it is best to remove the document feeder tray from the feeder as follows:

1. Push handle **A** downwards.

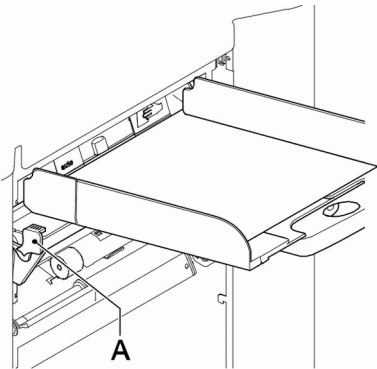

2. Lift the document feeder tray upwards to unhook it and then pull it out from the feeder.
3. Loosen the knob **B** half a turn.

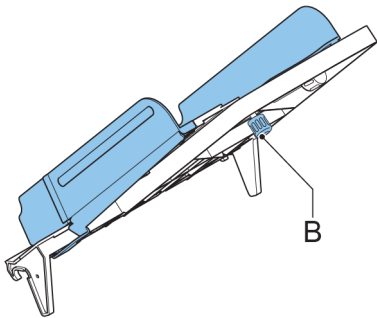

4. Grab the side guides in the middle and push them apart as far as possible.
 5. Put a small stack of documents between the side guides.
 6. Grab the side guides in the middle and push them towards the documents.
The space between the side guides and the documents should be such that the documents have just enough play to move freely.
 7. Re-tighten knob **B**.
 8. Remove the stack of documents.
 9. Replace the document feeder tray (see [Installing the Document Feeder Trays](#) on page 58).
-

Load Documents



Fill the document feeder tray as follows:

1. Open the left-hand side guide **A** by turning it downwards.
The feed rollers will automatically be lifted.

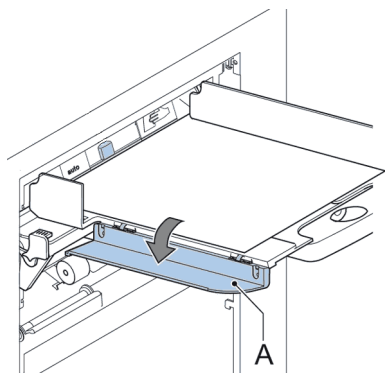

2. Place a stack of documents between the side guides.
3. Turn the left side guide upwards again.

Document Separation

The term 'Document separation' refers to the adjustment required for separating the upper document from the rest of the documents in the stack. This prevents pulling too much documents from the stack at the same time.

The document separation for the automatic feeders is set automatically; there are no manual adjustments needed.

Feeders 3st can be special feeders. The document separation for special feeders must be adjusted manually. While special feeder trays fit in all positions, adjusting the separation is only possible when they are fitted on position 1 and 2.

To adjust the separation of special feeders follow the instructions as described in [Adjust the Separation of Special Feeders](#) on page 46.

5

English

maxiFeeder

Adjust the maxiFeeder Side Guides



Adjust the side guides:

1. Take a stack of documents/BREs and place them in the feeder tray. BREs with flap down and leading (top side pointing to system).

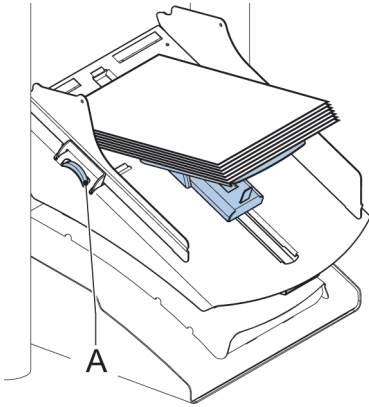

2. Adjust the side guides by turning the thumb wheel **A** such that the documents/BREs just fit and can move without resistance. Too much play causes skewing.

Adjust the maxiFeeder Document Separation



When the maxiFeeder is used at an automatic separation feeder, the separation is set automatically.
The maxiFeeder can also be used on a feeder position with a manually adjusted separation.
To adjust, proceed as follows:

1. Remove the document feeder trays 2 and 3.

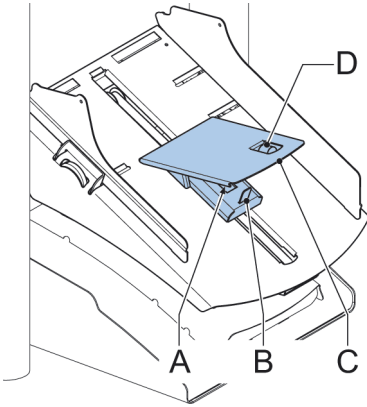

The lowest feeder is feeder 1.

2. Squeeze the two blue handles **A** and **B** and shift the feeding plate **C** as far as possible to the front.
3. Push knob **D** forward until it clicks.
4. Place a document/BRE on the feeder tray and slide it in the system till the leading edge is not visible anymore. Turn knob **D** counterclockwise if the separation is set to narrow.
5. Push the document/BRE between the rollers.
6. Turn knob **D** clockwise to get more resistance and counterclockwise if the separation is set to narrow.
The separation is adjusted correctly when a slight resistance is felt on the document/BRE.
7. Pull knob **D** back when ready.
8. Replace the document feeder trays 2 and 3.

Load Documents (maxiFeeder)



When loading the maxiFeeder, make sure that the document/BREs are positioned parallel in relation to the feeding plate assembly to ensure correct feeding.

The feeding plate assembly will be shifted up automatically (when the system starts processing) until documents/BREs are underneath the rubber paper pullers.



In case of long documents, use the feeding plate extension B to support the documents. Instead also an optional A4/11" paper guide can be used to support long documents. Ask your local distributor for more information about this optional paper guide.

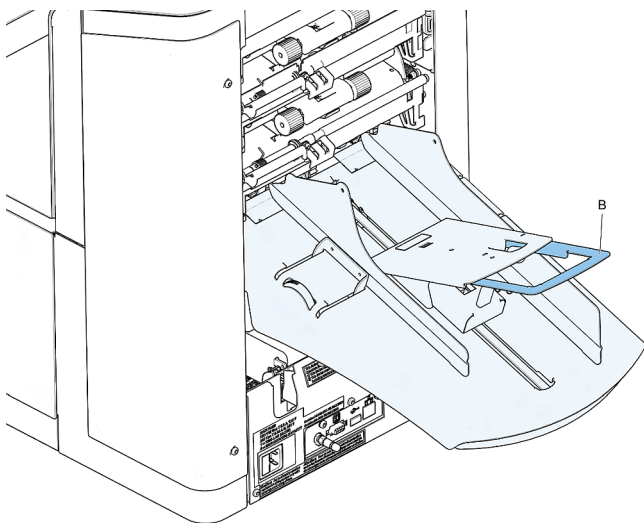

To load documents:

1. Squeeze the two blue handles **A** and **B**.

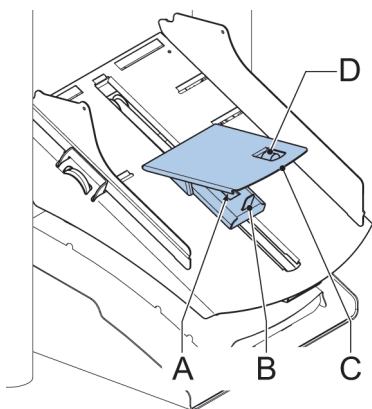

2. Shift the feeding plate assembly **C** to the rear position.
 3. Loosen the stack of documents and place them in the feeder tray. BREs with flap down and leading (top side pointing to system).
-

High Capacity Document Feeder

Adjust the Side Guides



To adjust the side guides B:

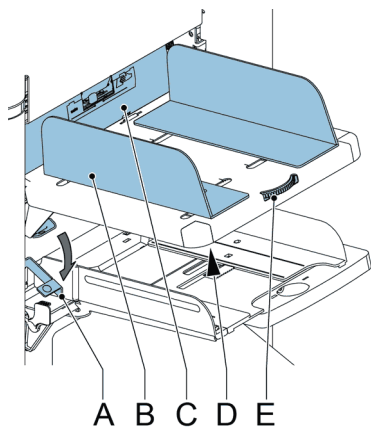

1. Loosen knob **D**, which is located underneath the feeder tray, half a turn.
2. Put a small stack of documents between the side guides.
3. Rotate wheel **E**.
The space between the side guides and the documents should be such that the documents have just enough play to move freely.

4. Re-tighten knob D.

Load Documents (HCDF)



To load the document feeder tray:

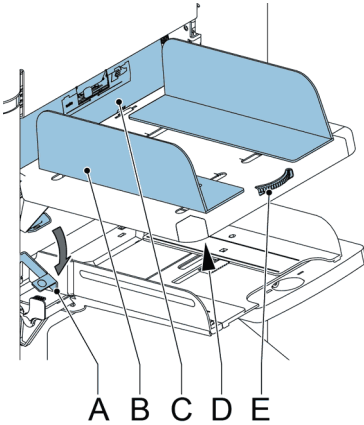

1. Pull down lever **A**.
The feeder rollers **C** move up to filling level.
2. Place a stack of documents between the side guides (max. 725 sheets, 80 g/m²).
See [Document Orientation](#) how to place the documents in the feeder tray.
3. Release lever **A**.

Adjust the Side Guides



The side guides can be adjusted as follows:

1. Place a stack of documents into the feeder tray.

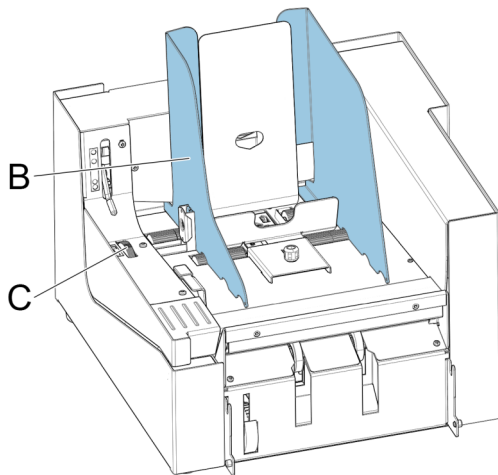

- Adjust the feeder tray side guides **B** by turning the thumbwheel **C**.

Provide just enough space for the documents to move freely. Too much play causes skewing.

Adjust the Document Separation



Check before the adjustment that the release handle **D** for the separation unit is in the closed (down) position.

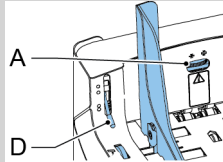

The document separation can be adjusted as follows:

- Turn the separation adjustment wheel **A** counter clockwise until a document can be moved backwards and forwards without resistance.

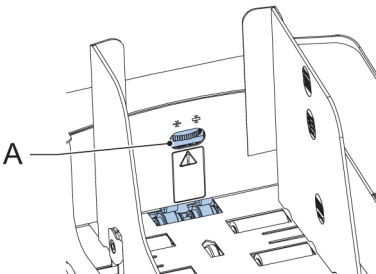

2. Turn the separation adjustment wheel clockwise until a slight resistance is felt on the document when the document is moved backwards and forwards.
3. Turn the separation adjustment wheel clockwise to get more resistance or counter clockwise to lower the resistance.
4. Check the separation before starting the system. After starting the system it may occur that more than one document at a time is pulled in. If this happens, turn the separation adjustment wheel more clockwise to obtain correct operation. For poor feeding turn the separation adjustment wheel counter clockwise.

Feeder Tray Capacity



To avoid irregular feeding there are three levels for the maximum heights of the feeder tray capacity. The symbols for these three levels are printed on the right hand side guide of the feeder tray. The level indication is a guideline.

	Maximum feeder tray capacity of booklets with a tough cover (maximum height: 250 mm).
	Maximum feeder tray capacity for booklets with a weak cover (maximum height: 150 mm).
	Maximum feeder tray capacity for single sheets: minimum sheet quality: 80 gr/m2 (maximum height: 50 mm).

Support for Curved Reply Envelopes (option for VersaFeeder)

Depending on the quality of the paper, the conditions during storage, etc. envelopes can be curved. This can cause smaller reply envelopes to skew while being processed by the VersaFeeder.

A special support is available to allow curved envelopes to be correctly processed. It can be used for envelopes with a height up to 110 mm (4.33").

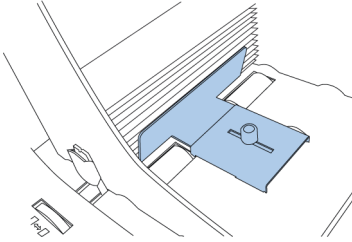

5

English

Load Envelopes



Before you load the envelopes, make sure the envelope separation and side guides are correctly set.

1. Rotate thumb wheel **D** to move the side guides **C** apart.

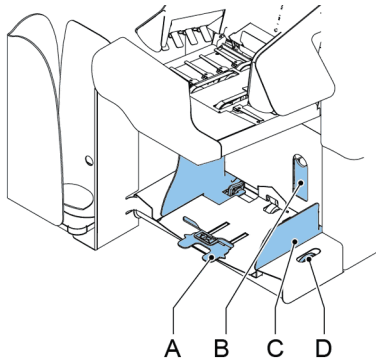

2. Pull down small lever **B** to set the separation.
3. Insert one envelope up to the stoppers. The position of the envelope is flap down and trailing (bottom side of the envelope pointing to the system).
4. Return lever **B**.
5. Loosen a stack of envelopes and place the stack on top of the bottom envelope between the side guides.
6. Move the side guides towards the envelopes.

The space between the side guides and the envelopes should be such that the envelopes have just enough play to move freely.



If the distance between the side guides is too large, the envelopes will twist sideways, when transported into the machine.

- Shift the envelope support in or out. The top side of the envelope must touch the dotted line on the support.

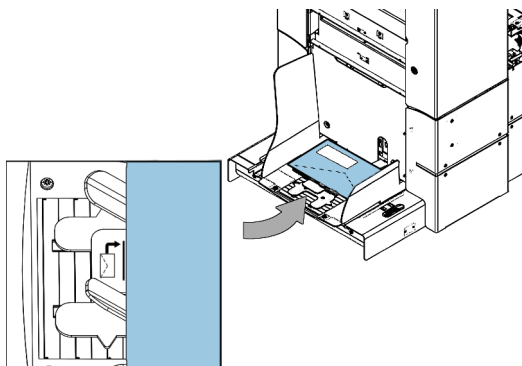

- Turn the envelope support to distribute the weight of the envelopes evenly on both sides.

Filling the Sealing Liquid Reservoir



When you want to seal envelopes, the sealing liquid reservoir must be filled.

- Open the front cover **A**.

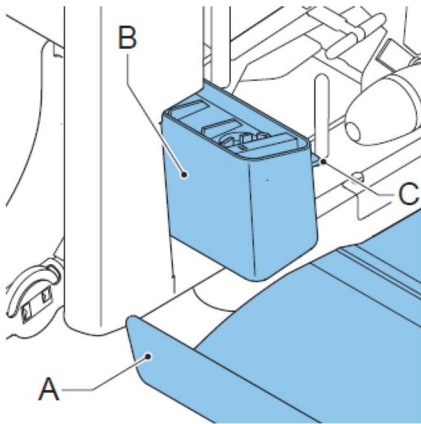

2. Fill the reservoir **B** up to lip **C** with sealing liquid.
3. Close the front cover **A**

Before you start the job, wait approximately 5 minutes for the brushes to moisten.

If the liquid reservoir is almost empty the touchscreen shows a message to warn you that you should refill the reservoir.

6 Settings menu

Open the Settings Menu

In the settings menu for the operator it is possible to edit the display settings and to set the localisation.

If you want to view or edit any of the Operator Settings:

1. Go to the Job list and tap the side menu on the left side and select **[Settings]**.

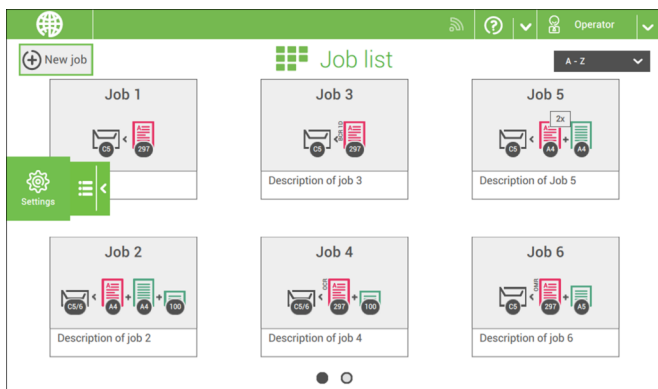

2. Tap **[Localisation]** if you want to change the document standard, weight standard or the language.

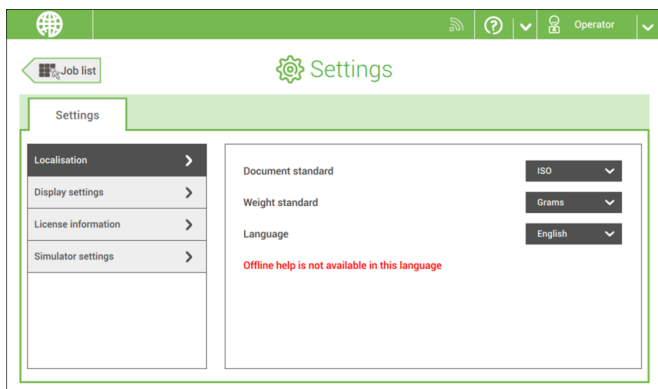

6

English

3. Tap **[Display settings]** if you want to:

- set the 'Key' click to on/off
- set the Volume
- set the Backlight
- set the Brightness

To set the backlight and brightness, a test pattern is available as a reference.

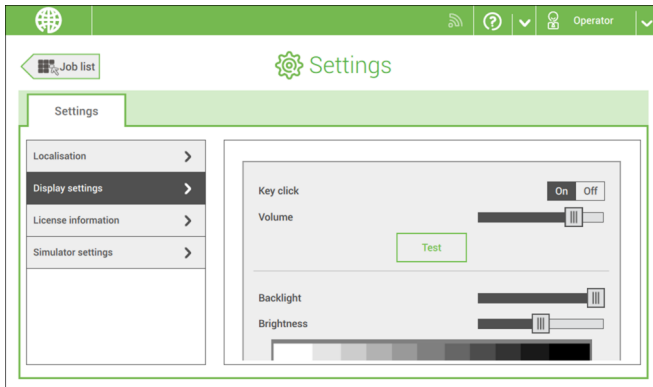

For more information on Open source licenses, see [License information](#).

The Settings Menu Supervisor

Supervisor Settings are all settings that can be found under the Settings Menu when logged in as supervisor (pin code 2546). The following flowchart shows which subjects are available via the Supervisor settings menu. It is possible to view or edit any of the Supervisor Settings.

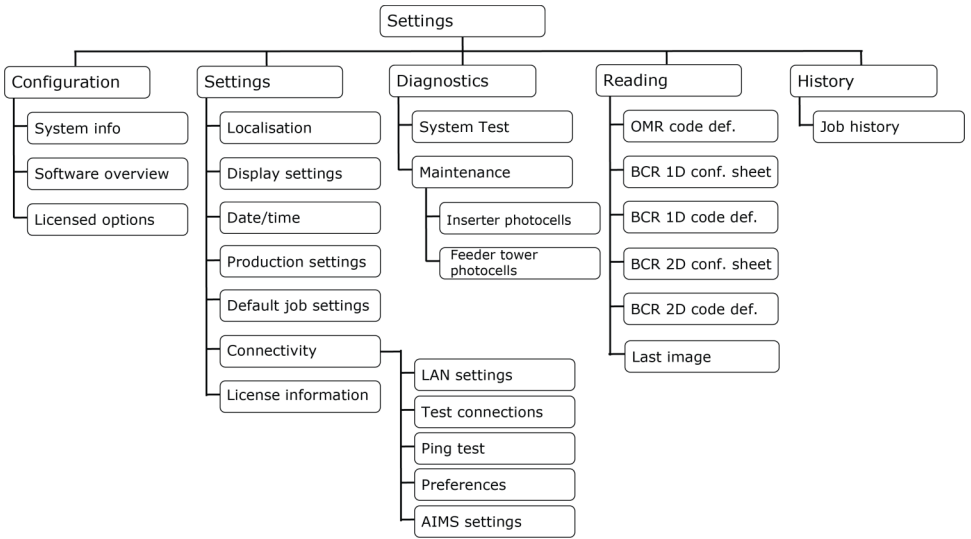

Supervisor Settings Menu

Open the Settings Menu (Supervisor)

If you want to view or edit any of the Supervisor Settings:

1. Login as Supervisor with pin code **2546**.

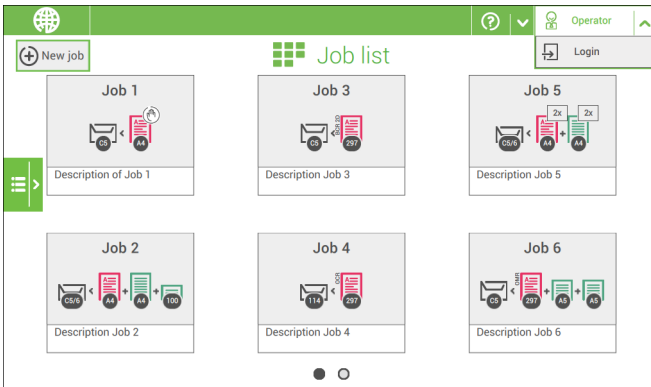

2. Go to the Job list and tap the side menu on the left side and select **[Settings]**.

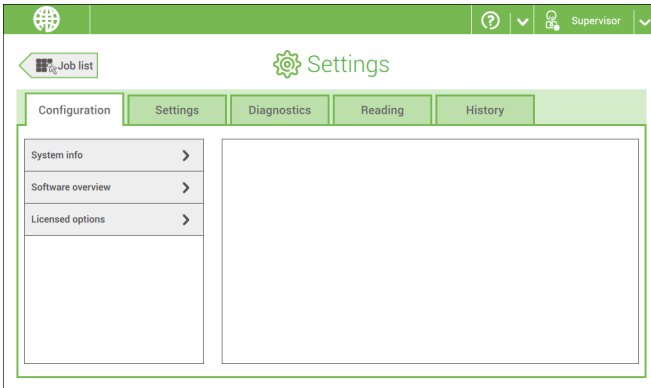

Configuration

Configuration

The Configuration menu contains the configuration information settings for the system.

System Info

The System info part of the Configuration menu shows the following information:

- Flex certificate - this option is used for reading
- Counter since last visit - the counter value since the last service visit
- Last error (description) - The last error and error description generated by the system

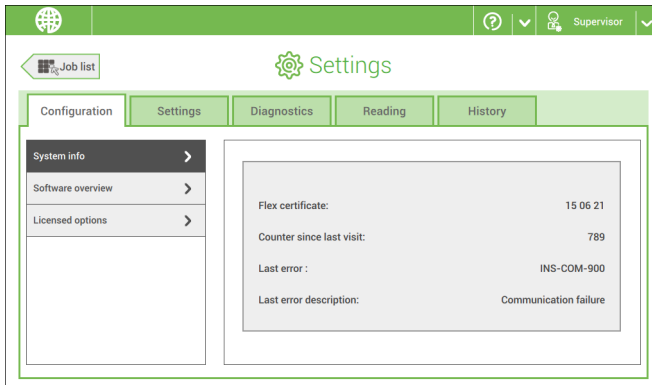

Software Overview

The Software overview part of the Configuration menu shows the versions of the software that is present in the total system.

The screenshot shows the 'Settings' application interface. The top navigation bar includes a globe icon, a help icon, and a 'Supervisor' dropdown menu. Below the navigation bar, there is a 'Job list' button and the 'Settings' title. The main content area has tabs for 'Configuration', 'Settings', 'Diagnostics', 'Reading', and 'History'. The 'Settings' tab is active, showing a left-hand navigation menu with 'System info', 'Software overview', and 'Licensed options'. The 'Software overview' section is expanded, displaying a table of software components under the 'Inserter' category. The table lists the following components:

Package Id: Project version			
Inserter			
DS Control MMI A0092528	J	V2.10	64155
DS Control FS A0018480	Z		000
DS Control OS A0007519	Z		000
Inserter A0007514	Z	V1.66	3461

Below the table, the 'FeederTower' section is visible but empty.

6

English

Licensed Options

The Licensed options part of the Configuration menu shows the following information:

- Chip ID
- Serial number
- Installed options

The installed options are enabled with license codes. These license codes, together with the identification number of the machine enable the relevant options. The enabled and available software options are displayed in this screen. Contact your dealer for information about these license codes.

The system supports the following licensed options:

- Remote assistance
- Online help
- Advanced/Basic reading
- OMR 1 track
- BCR 1D/2D
- Flex reading
- MaxiFeeder

The screenshot displays the 'Settings' interface. At the top, there is a green header bar with a globe icon, a help icon, and a user profile labeled 'Supervisor'. Below the header, a navigation bar contains 'Job list' and 'Settings' (with a gear icon). The main content area is divided into tabs: 'Configuration', 'Settings', 'Diagnostics', 'Reading', and 'History'. The 'Settings' tab is active, and the 'Licensed options' section is selected in the left sidebar. The main panel shows the following information:

Chip ID	00-01-02-03-04-05-06-07
Serial number	15PR7777
License code	- - - Add
OMR	Enabled
MPPC	Enabled
AIMS	Level 1

Online Feature (Licenses) Management

At powerup the system does an online check, provided that it is connected to a network, to determine if new features have become available or if the licensed features are still active. If for example the license end date is nearing, the machine will give a popup which license(s) almost expire(s).

This will be shown once a week within the last month of the license.

An example of such a message is shown below.

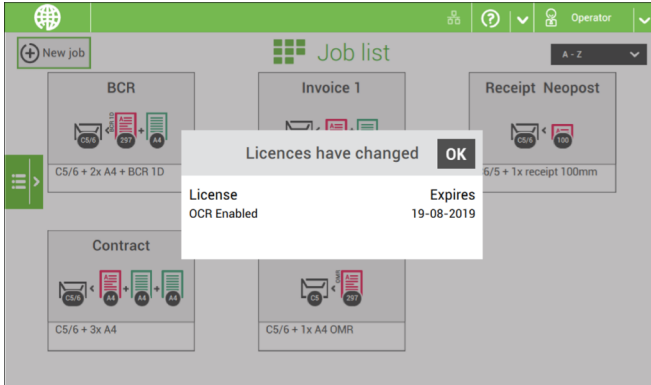

As such message is just meant as notification just tap OK and the message will disappear.



Licenses, either permanent or temporary, will be installed automatically.



When a temporary license has expired contact your dealer or sales representative for more information.

Add a Licensed Option

To add a licensed option:

1. In the Configuration, Licensed options screen, enter the license code.

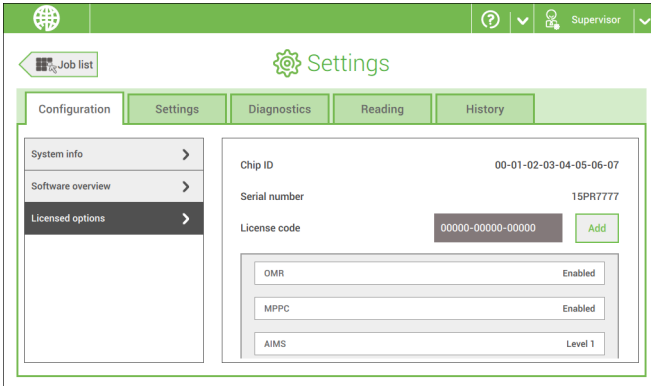

2. Tap **[Add]**.

The system verifies the license key.

If the license key has been verified successfully, the option is added to the system and can be used.

Settings

Settings

The Settings menu contains the configuration settings for the system.

Localisation

Tap **[Localisation]** if you want to change the document standard or the language.

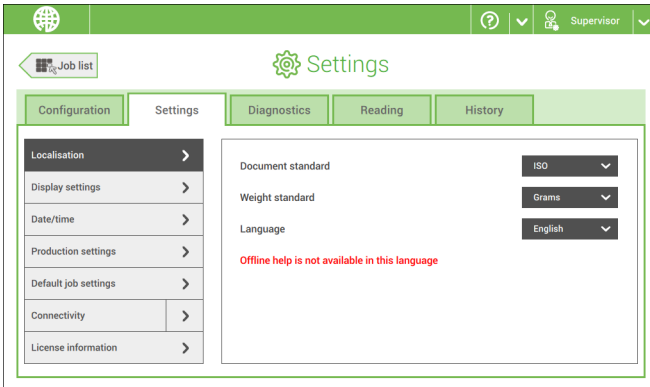

When you need a keyboard to enter e.g. a job name, you get a special keyboard in case of Russian, Czech and Katakana. But the keyboard has always a button to switch back to the English keyboard.



Display Settings

See [the settings menu for the operator](#) on page 76.

Date-time

Tap **[Date/time]** to set the:

- Date
- Time
- Date format; you can choose between three format to show the date: dd-mm-yyyy, mm-dd-yyyy or yyyy-mm-dd
- Time format; you can choose between a '12 hours' notation or a '24 hours' notation

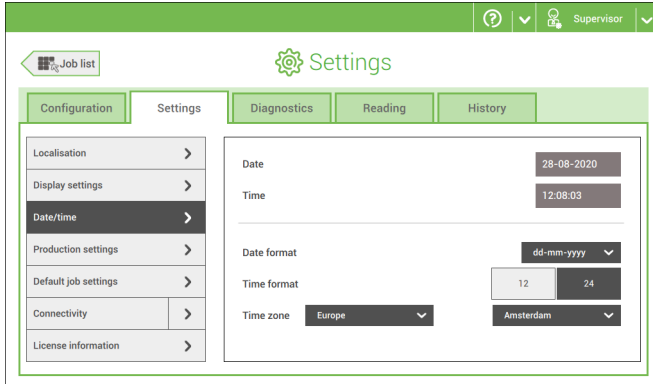

When the system is connected to the internet the time is synchronized automatically. Make sure to setup the time zone correctly.

Production Settings

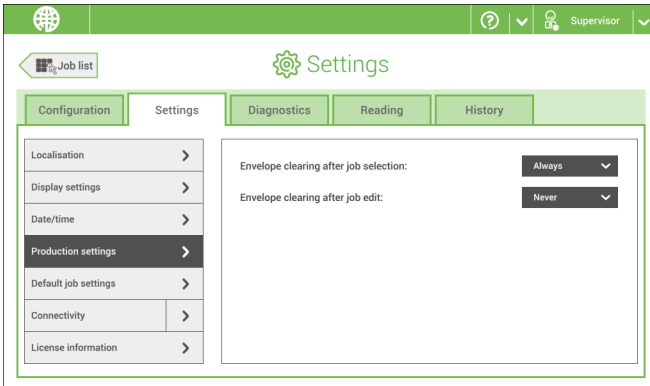

The Production Settings part of the Settings Menu covers settings regarding the clearing of the envelope track.

The screen shows two options:

- Envelopes clearing after job selection: this setting defines if the envelopes should be cleared when you select a job. 'Ask' means that the system asks if you want to clear the envelopes.
- Envelopes clearing after job edit: this setting defines if the envelopes should be cleared when you have edited a job. 'Ask' means that the system asks if you want to clear the envelopes.

It makes a difference if you switch from a job to another (existing) job from the job list or if you start creating a new automatic job.

The pull down menus show three options:

- Always
- Ask
- Never

Tap [**Production settings**] to define when envelopes should be cleared from the system.

- Envelopes clearing after job selection: this setting defines if the envelopes should be cleared when you select a job. 'Ask' means that the system asks if you want to clear the envelopes.
- Envelopes clearing after job edit: this setting defines if the envelopes should be cleared when you have edited a job. 'Ask' means that the system asks if you want to clear the envelopes.

Switch to an existing job

If the user selects "**Always**"; after tapping 1x or Start: the system shows a popup asking to clear the envelopes or continue without clearing. The following two options are possible:

1. The user chooses to clear the envelope:
 - a. The system start transporting envelopes present in the system to the exit. For safety a maximum number of envelopes is processed. This maximum is set to 3.
 - b. If the system still detects envelopes after the maximum is reached, the system shows a warning (INS-EH1-002) that there are still envelopes in the hopper that should be removed.
 - c. When the user cancels the dialog with the 'X', the system returns to the Idle screen without clearing or producing.
 - d. After clearing, the system returns to the idle screen.
2. The user chooses to continue without clearing:
 - a. The system starts producing with the envelopes loaded in the system.

If the user selects "**Ask**"; after tapping 1x or Start: the system shows a popup asking to clear the envelopes or continue without clearing. The following two options are possible:

1. The user chooses to clear the envelope:
 - a. The system start transporting envelopes present in the system to the exit. For safety a maximum number of envelopes is processed. This maximum is set to 3.
 - b. When the user cancels the dialog with the 'X', the system returns to the Idle screen without clearing or producing.
 - c. After clearing, the system returns to the idle screen.
2. The user chooses to continue without clearing:
 - a. The system starts producing with the envelopes loaded in the system.

If the user selects "**Never**" and envelope settings have not been changed; after tapping 1x or Start: the system starts producing with the envelopes loaded in the system.

If the user selects "**Never**" and envelope settings have been changed; after tapping 1x or Start: the system shows a popup asking to clear the envelopes or continue without clearing. The following two options are possible:

1. The user chooses to clear the envelope:
 - a. The system starts transporting envelopes present in the system to the exit. For safety a maximum number of envelopes is processed. This maximum is set to 3.
 - b. When the user cancels the dialog with the 'X', the system returns to the Idle screen without clearing or producing.
 - c. After clearing, the system returns to the idle screen.
2. The user chooses to continue without clearing:
 - a. The system starts producing with the envelopes loaded.

Create a new automatic job

If the user selects "**Always**"; after tapping 1x the system shows a popup asking to clear the envelopes or continue without clearing. The following two options are possible:

1. The user chooses to clear the envelope:
 - a. The system starts transporting envelopes present in the system to the exit. For safety a maximum number of envelopes is processed. This maximum is set to 3.
 - b. If the system still detects envelopes after the maximum is reached, the system shows a warning (INS-EH1-002) that there are still envelopes in the hopper that should be removed.
 - c. When the user cancels the dialog with the 'X', the system returns to the Idle screen without clearing or producing.
 - d. After clearing, the system returns to the idle screen.
2. The user chooses to continue without clearing:
 - a. The system starts producing with the envelopes loaded.

If the user selects "**Ask**" or "**Never**"; after tapping 1x: the system shows a popup asking to clear the envelopes or continue without clearing. The following two options are possible:

1. The user chooses to clear the envelope:
 - a. The system starts transporting envelopes present in the system to the exit. For safety a maximum number of envelopes is processed. This maximum is set to 3.
 - b. When the user cancels the dialog with the 'X', the system returns to the Idle screen without clearing or producing.
 - c. After clearing, the system returns to the idle screen.
2. The user chooses to continue without clearing: the system starts producing with the envelopes loaded.

Default Job Settings



Job settings normally will be changed by a service engineer only. Therefore first consult the service organization before you change any settings. Changes to the job settings can result in malfunctioning of jobs.



You can also define the job settings per job. Select a job from the Job list, tap Edit, navigate to the Exit settings, and tap "Advanced".

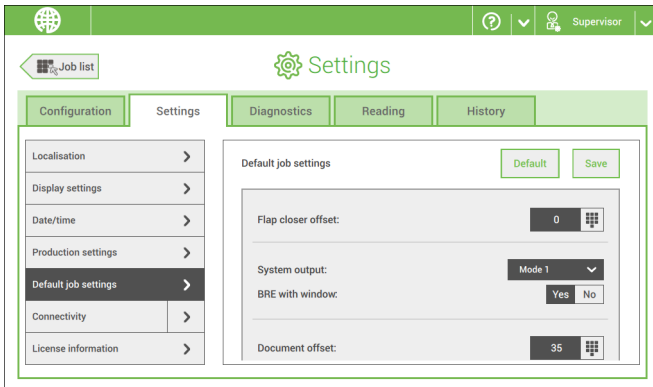

The Job settings part of the Settings menu covers settings that improve the processing of jobs:

- **Flap closer offset:** to improve the sealing of specific envelopes you can delay or advance the moment of sealing. You enter the number of pulses. A minus value means the sealing is advanced, a plus value means the sealing is delayed. You can enter a number between -20 and 20.
- **System output:** mode 1 mode 2
 Mode 1 focuses on the versatility of paper parameters (paper thickness; document length), i.e. correct operation under even extreme paper conditions. Mode 2 is the default mode, and focuses on high speed. Use Mode 1 with a paper thickness of 65 g/m² or less, a document length of 12 inch (305 mm) or higher, and for situations where Mode 2 is not functioning properly. In all other cases use Mode 2.
- **BRE with window:** if the BRE has a window, set this setting to yes. Only available with Mode 2.
- **Document offset** (A in the figure): the extend to which documents are not overlapping in the vertical transport. In the vertical transport of documents fed by the various feeders, the documents are partially overlapping each other. This to make sure that the documents are properly aligned in the collator area. The default value is 50 mm (2.0 inch). The document offset can be varied between 20 mm (0.8 inch) and 250 mm (9.8 inch).

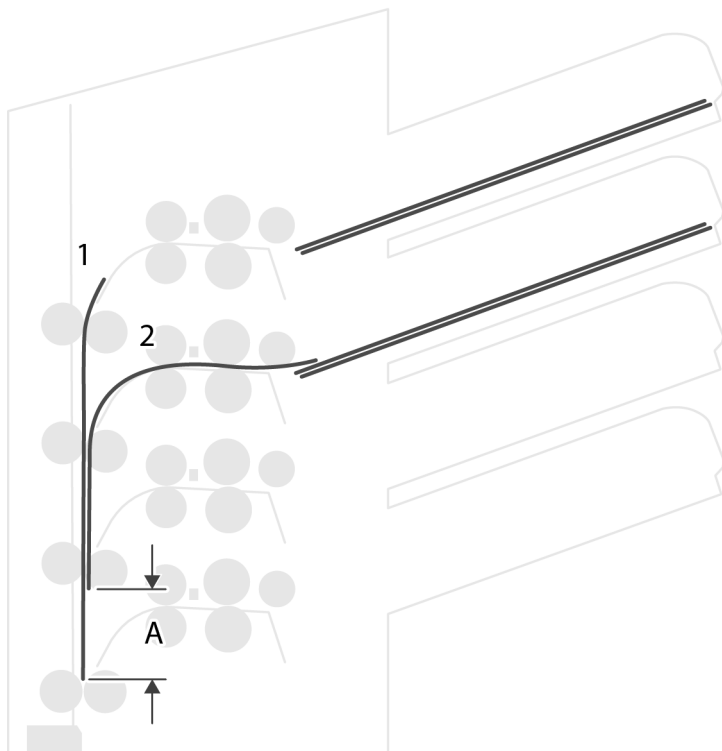

- **BRE offset:** in the case of offset is "yes", the last document that was added to the set is shifted from the rest of the set (offsetting, see below).
- **Collator stop optimisation:** if set to "off", the system does not show a message, when a collator stop change can improve the system output.

Explanation of BRE offset: if a BRE is longer than the set fold but shorter than the envelope height, this BRE can get folded (A in the figure). Under certain conditions (see below) you can prevent the BRE from being folded. In the case of offset "yes", the BRE is held back during a certain distance (B in the figure). This means that the trailing edge of the BRE leaves the collator last. The document is not folded. During the insertion into the envelope the documents of the set are aligned.

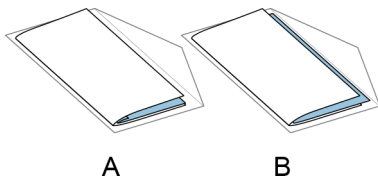

A

B

The conditions are:

- No multi-feed is used for the BREs.
- The document directly under the BRE must have a height of at least 60 mm (2.4 inch) more than the BRE.
- The height of the BRE is more than the set fold length.
- The folding mode is either V-fold or C-fold (no Z-fold).
- The BRE must be shorter than the envelope height.

The whole BRE offset is based on friction between documents within a set. Therefore it is necessary to make use of these conditions to reduce the risk of bad transporting, folding and inserting.



It is possible to use the BRE offset for a BRE and an enclosure (card) in one set. The extra condition is that this enclosure is equal to or smaller than the set address fold and should be placed direct underneath the BRE in the set.

Connectivity

For more information about the connectivity of the system refer to the section "Connect the system to the internet".

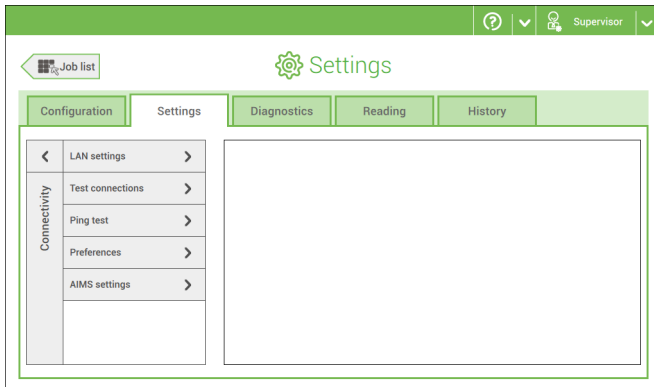

License information

License information shows information on the open source software that is used in the system.

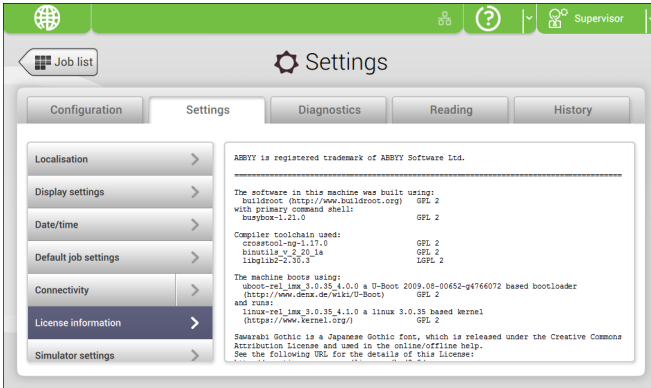

6
English

Diagnostics

Diagnostics

The diagnostics menu contains the basic diagnostics functions available for a supervisor.

System Test

Use the **[System test]** to check if all motors, clutches and sensors are correctly connected. The test briefly activates the actuators and clutches and measures the current.

To run a system test:

1. In the Settings menu, tap the **[Diagnostics]** tab.
2. Tap **[System test]**.

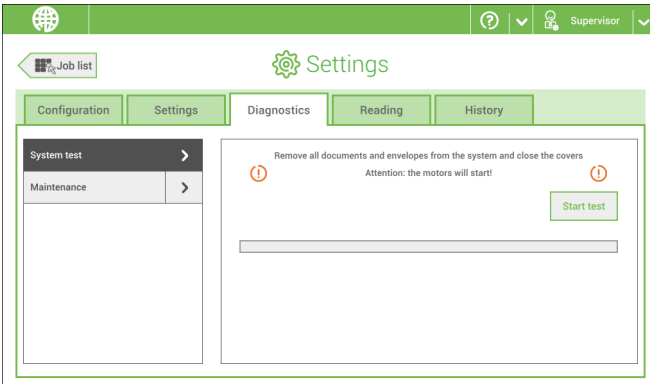

3. Remove all documents and envelopes and close all covers before starting the diagnose.
4. Tap **[Start test]**.
5. When the test is finished, the Status report is shown, showing a list of all problems found during diagnostics. If tests fail, contact your service organization.

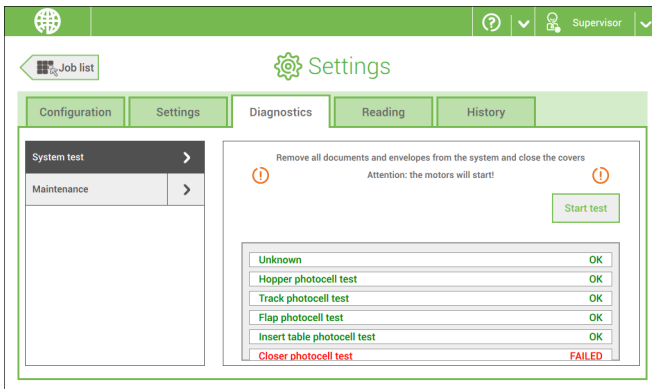

Maintenance

When too much paper dust is built up at the sensors a warning message will be displayed. To check the conditions of the photocells or to calibrate them follow the instructions as described in [Calibrate photocells](#).

Reading

Reading

The reading menu contains the configuration items for the reading functions. Because reading is optional, this menu is only available when there is at least one reading license present. For more information on the reading option, see [Reading](#).

OMR Code Definition

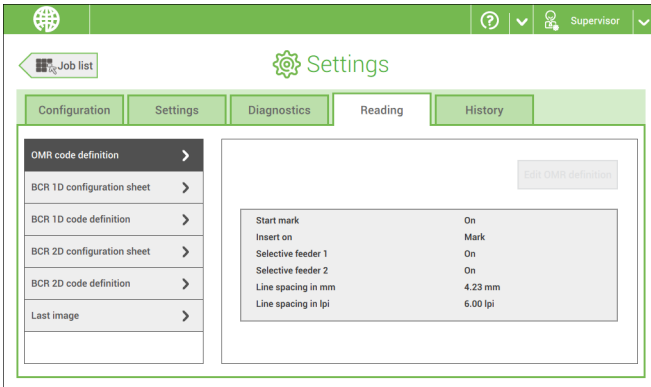

The Reading OMR code definition screen shows the configuration of the system for OMR. For every OMR code option, it shows if it is on or off. If it is on, the screen shows information on what the system does, when it reads a mark or no mark.

BCR 1D Configuration Sheet

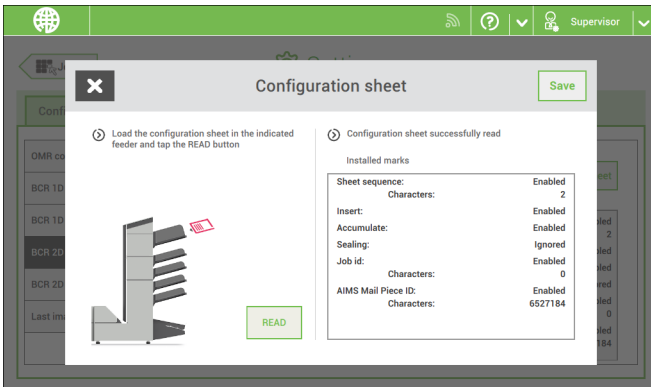

The Reading BCR 1D configuration sheet allows you to read a configuration sheet. The result is visible in this screen, but also in the BCR 1D code definition screen. See [Reading a configuration sheet](#).

BCR 1D Code Definition

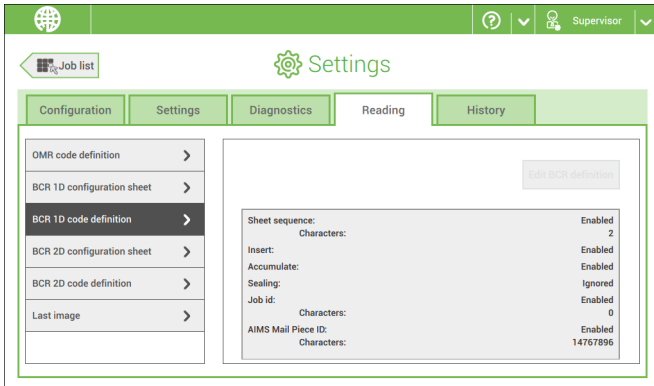

The BCR 1D code definition screen shows only information when a configuration sheet is read. It shows which codes are enabled and how they work.

BCR 2D Configuration Sheet

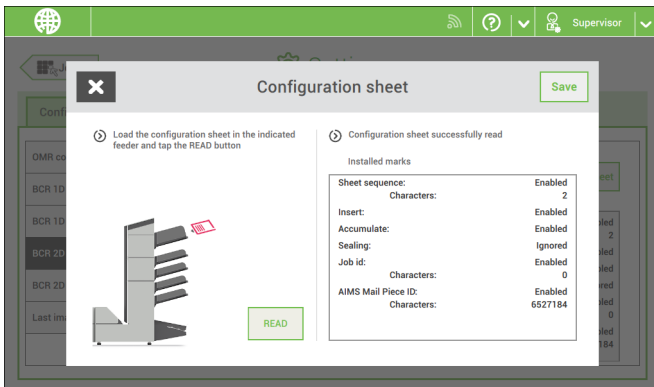

The Reading BCR 2D configuration sheet allows you to read a configuration sheet. The result is visible in this screen, but also in the BCR 2D code definition screen. See [Reading a configuration sheet](#).

BCR 2D Code Definition

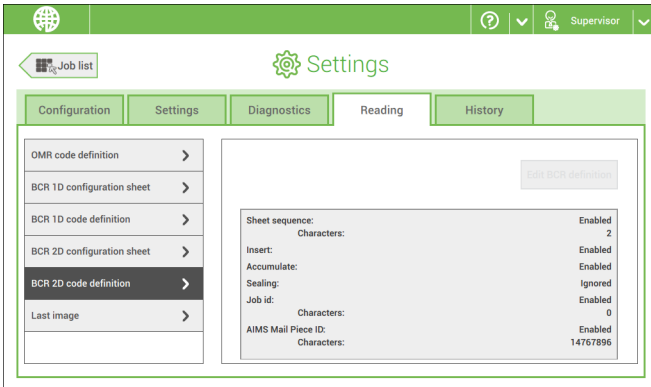

The BCR 2D code definition screen shows only information when a configuration sheet is read. It shows which codes are enabled and how they work.

Last Image

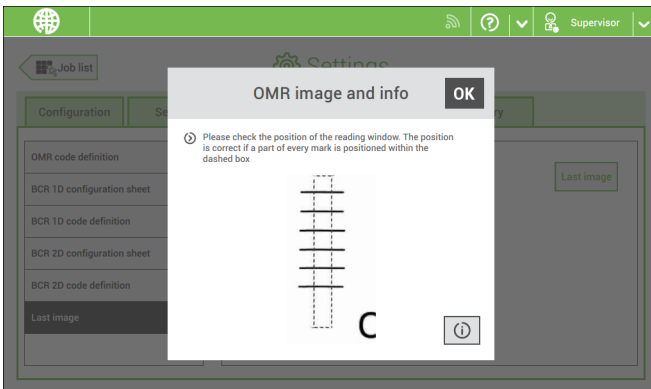

The Last image screen shows the result of the last code that the system read. The figure shows an example of the image of an OMR code. You can use this image to see if the read code fits within the reading window.

When you click on the Information button of an image of OMR code, the screen shows a graphical representation of the marks read from the last OMR document (oscilloscope function). It shows the time-dependant OMR output voltage.

History

The History screen shows an overview of the jobs run.

1. Tap on the **[History]** tab to view the Job history.

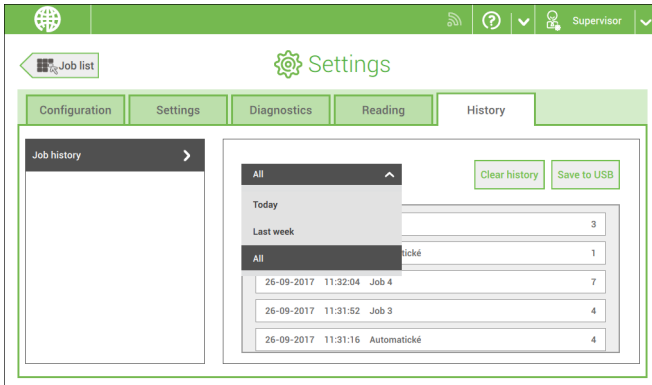

2. Tap on the **[Today]** pull down button if you want to view the jobs that are run 'Today', 'Last week' or 'All'.

The history is displayed on the touch screen. With **[Save to USB]**, you save the history in CSV format to a USB drive.

7 Connect the System to the Internet

Options for Connection

Connect the system to the internet in one of the following ways:

- Wired connection with the gigabit ethernet connection:
 - Connect with DHCP (Automatic IP address)
 - Manual Configuration
- Wireless connection:
 - Search for SSID
 - Manually configure SSID

In all cases, you can use proxy for the connection.



Log on as Supervisor to complete this procedure.

Set up a Wired Connection

Set up a wired connection as follows:

1. Connect the system to a LAN with a network cable. The figure shows the LAN connector (**B**).

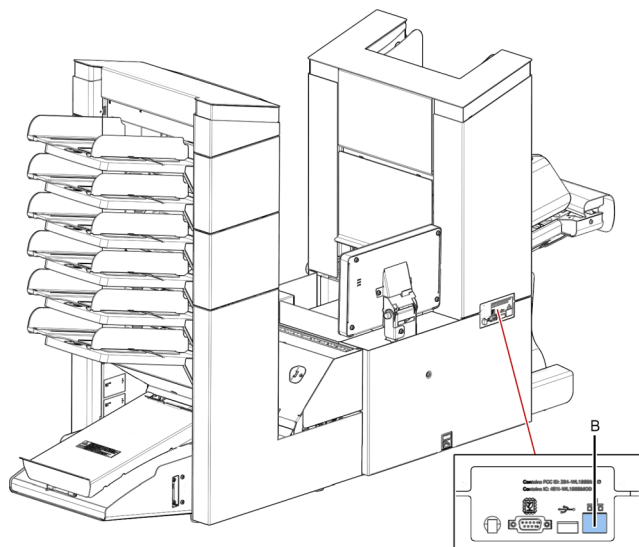

2. Open the supervisor settings menu.
3. Tap the Settings tab, [**Connectivity**].
4. Tap [**LAN settings**].

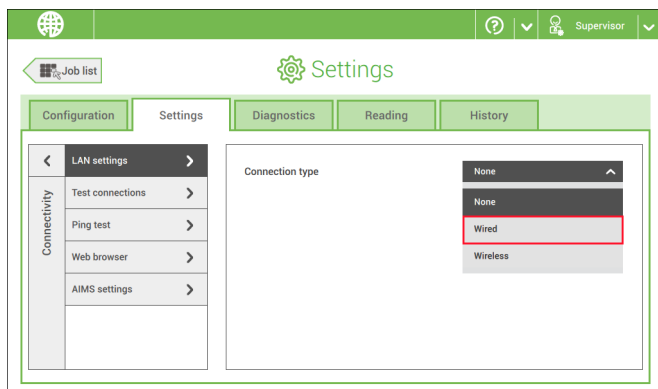

5. Select **Wired** from the **Connection type** pulldown menu.

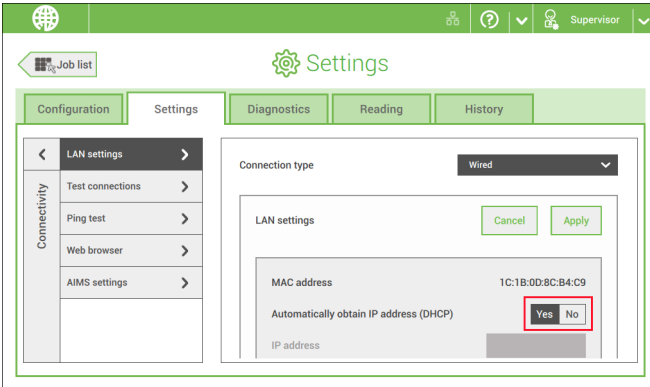

6. Set **Automatically obtain IP address (DHCP)** to **Yes** or **No**. If Yes, the system connects automatically to the LAN. If No, set up a connection manually. Enter the necessary details to setup a manual connection.

Set up a Wireless Connection

Set up a wireless connection as follows:

1. Open the supervisor settings menu.
2. Tap the Settings tab, [**Connectivity**].
3. Tap [**LAN settings**].

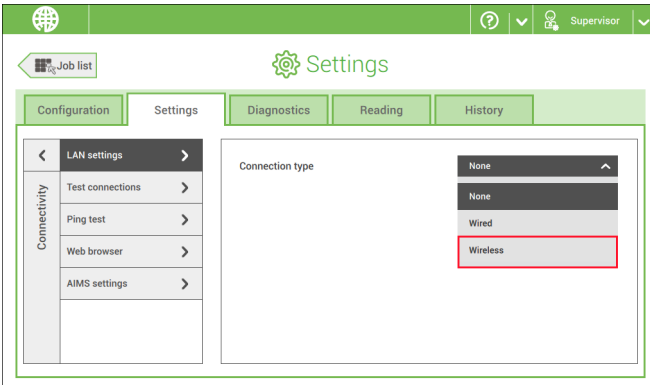

4. Select **Wireless** from the **Connection type** pulldown menu.

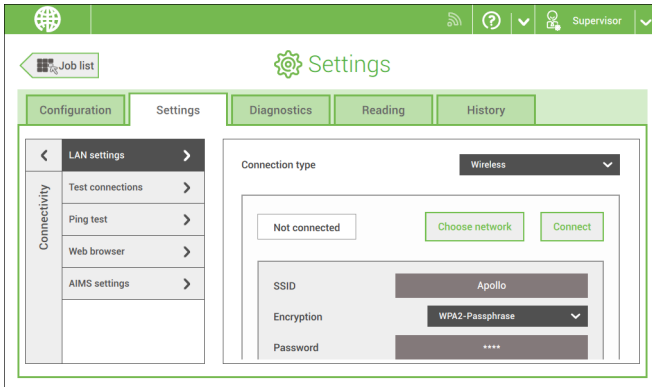

5. Choose if you want to enter the SSID manually or if you want to search for a wireless network. If you want to search for a network, tap [**Choose network**].
6. When you have entered the network details or selected a network from the search, tap [**Connect**] to connect to the network.

When the system connected successfully to the network, the screen shows Connected.

Test the Connection

When you have connected to a network, test the connection as follows:

1. Open the supervisor settings menu.
2. Tap the Settings tab, [**Connectivity**].
3. Tap [**Test connections**].

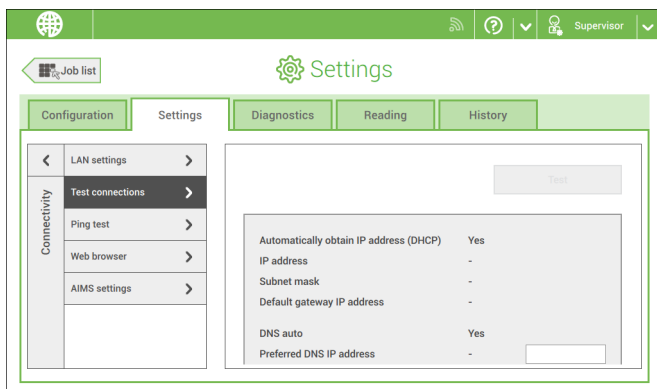

4. Tap the [**Test**] button.

The system tests the IP addresses that are defined at the LAN settings. If the result is 'Not OK', make sure that the settings are correctly defined.

AIMS settings

When operating with AIMS Verification, the server address and port can be configured and the connection to the AIMS server can be tested.

Contact your local distributor for more information about the AIMS option.

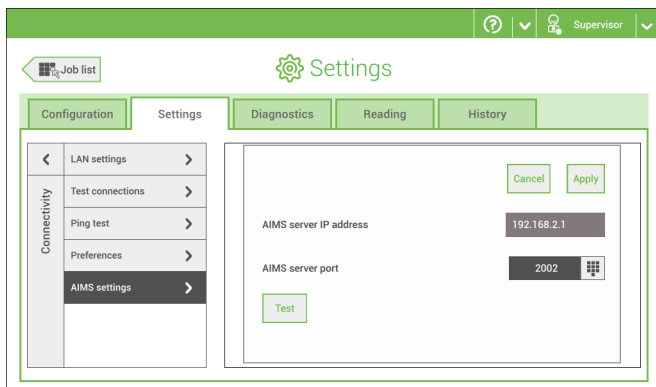

8 Reading

Introduction

Code Types

The reading option allows the system to read special codes that are printed on the documents. The code contains information about the processing of the documents.

The system can read the following code types:

- BCR 1D: One dimensional barcode
- BCR 2D: Two dimensional barcodes
- OMR: 1-track Optical Mark Recognition
- Flex 1-9: Optional translation to support non standard OMR and BCR coding

Depending on the settings, the code tells the system if:

- The document set is complete
- Enclosures must be added to the set
- The system must stop
- The set is complete (no pages are missing)
- The envelopes are transported to the side exit or to the stacker

The sheets with the printed code are placed in a feeder. Depending on the programmed code, the other feeders can be used as selective feeders to add enclosures.

In case of a Z-fold, the address has to be printed on the last page of the set. With the other fold types, the first sheet of a set always contains the address. A full length code is printed on every sheet of a set. The code must appear at the same location on every page regardless of the actual code length.

The code on the last sheet of the set contains the insert instruction. The other sheets carry the accumulate instruction. If the "Page N of M" code is used with BCR, the set will be inserted when N equals M.

General Requirements for Printing Codes

If you print documents for reading:

- Make sure the ribbon or toner quality is sufficient.
- Print the code in black on white background.
- Codes on the same sheet must have equal intensity.
- Print the code at the same position on every sheet.
- Be aware of "background noise". The reading function can be disturbed by: color changes on the form, background design and a logo or copy on the opposite side of the sheet that will bleed through.
- For matrix printers near letter quality (NLQ) printed characters are preferred to obtain maximum blackness (double strike).



For more information on how to print a reading code on your document, contact your service organization.

88

English

BCR Code Description

Bar codes are used for mail sets that are processed in Document Systems. The bar codes tell the system if:

- The document set is complete
- The envelope should be sealed
- Enclosures should be added
- Etc.

Barcode can be printed vertically and horizontally. Two types of barcodes are supported, 1D and 2D barcodes (depending on installed licenses).

Supported 1D barcodes

Code 39



Interleaved 2 of 5



Code 128, horizontal printed



Note: A **vertical** printed "Code 128" is **not** supported. It may work but it is not recommended because it is very sensitive to speed variations.

- Minimum line thickness of a bar: 0,20 mm (0.008")
- Maximum line thickness of a bar (smallest element): 0,50 mm (0.02")
- The thickness ratio of thick bars versus thin bars: 2.2
- Preferred print quality: 600dpi
- Minimum width of the barcode: 5 mm (0.2")
- Maximum qty. of characters: 109
- Quiet zone (free white space area): 5 mm (0.2").

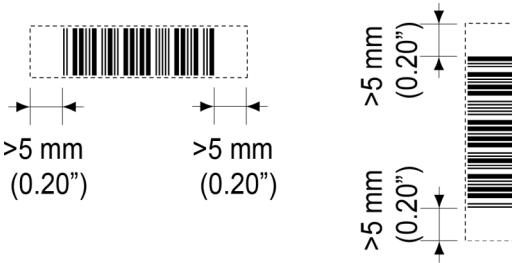

Supported 2D barcodes

Datamatrix



- Minimum cell size 0,30mm (0.012")
- Maximum cell size 0,50mm (0.02")
- Label size 30mm (1.18") square max
- Preferred print quality 600dpi
- Print drift from page to page +/- 2mm max
- Colour background: White
- Datamatrix can be read in all directions
- Minimum white space 2mm (0.08"), all around.

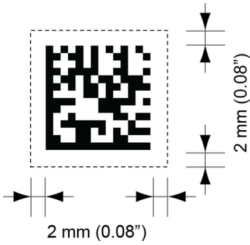

88

English

QR



- Minimum cell size 0,30mm (0.012")
- Maximum cell size 0,50mm (0.020")
- Label size 30mm (1.18") square max
- Preferred print quality 600dpi
- Print drift from page to page +/- 2mm (0.08") max
- Colour background: White
- QR can be read in all directions
- Minimum white space 4mm (0.20"), all around.

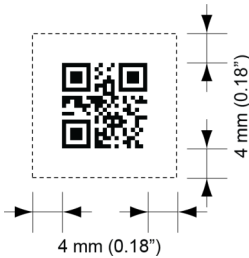

PDF 417



- Bar width 0,35 mm (0.014") min
- Smallest element size 0,5 mm (0.020") max
- Preferred print quality 600dpi
- Print drift from page to page +/- 2mm max
- Colour background: White
- Minimum white space 2mm (0.08"), all around.



Printing contrast

The label must be strongly printed in black on white background for maximum contrast. Other light backgrounds may be acceptable, subject to test.

Position of the code on the document

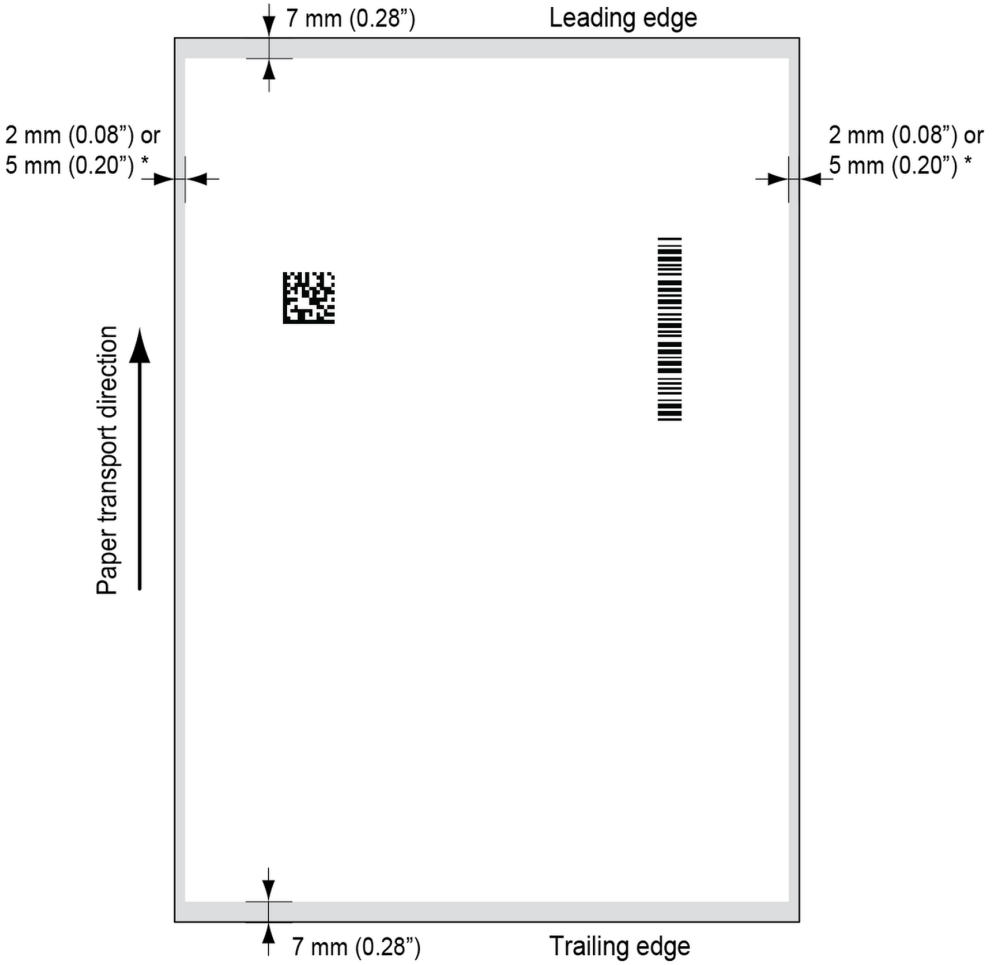

Leading and trailing margins

Barcode should be positioned at least 7 mm (0.28") from the trailing and leading edge of the sheet.

LH and RH margins *

Document width ≤ 210 mm, maintain at least 2mm (0.08") clearance from both side edges.
Document width > 210 mm, maintain at least 5mm (0.2") clearance from both side edges.

Increased Reading Speed

To obtain an increased reading speed, resulting in a higher output, the following requirements should be met:

- the reading marks / barcode should be printed between 7 mm and 85 mm measured from the top of the sheet;
- do not use (selective) enclosures.



BCR license types

There are two BCR license types:

- Basic
- Advanced

BCR basic license

For the BCR basic license the following functions are available:

- Page N of M: as long as N is below M, the document set is not complete. As soon as $N=M$, the set is complete and will be inserted into an envelope.
- Insert/Accumulate: defines when a document set is complete and must be inserted into an envelope.
- Customer ID: BCR uses the Customer ID code to complete a set. If the ID changes, the set is inserted. This is only possible with reverse reading (First of group).

At least one basic commands is required. Page N of M can be used in combination with Customer ID as an integrity check.

BCR advanced license

For the BCR advanced license the following functions are available:

- The basic functions (insert/accumulate, Customer ID).
- Sheet sequence - Every sheet has a number, regardless of the document set it is part of. If a sheet is missing, an error is generated.
- Group sequence - Every document in a set has the same group number. If one document set is missing, an error is generated.
- Divert (Divert & Continue) - The set will be diverted and the system continues.
- Stop (Divert & Stop) - The set will be diverted and the system stops indicating error (FT1-RE1-000 Reading stop - Stop mark read).
- Selective feed - If the system reads the command, an enclosure from the enclosure feeder is added to the set. This function is printed on the last sheet of a set. It is also possible to add an enclosure from the versaFeeder(s).
- Sealing control - Determines if envelopes are sealed or not.
- Present on Deck & Continue - The set leaves the system from the upper unit. The system does not stop processing. The envelopes are not sealed.
- Present on Deck & Stop - The set leaves the system from the upper unit. The system stops. The envelopes are not sealed.
- Exit selection - Determines if the envelope is transported to stacker or to the side exit.

OMR Code Description

Position of the code on the document

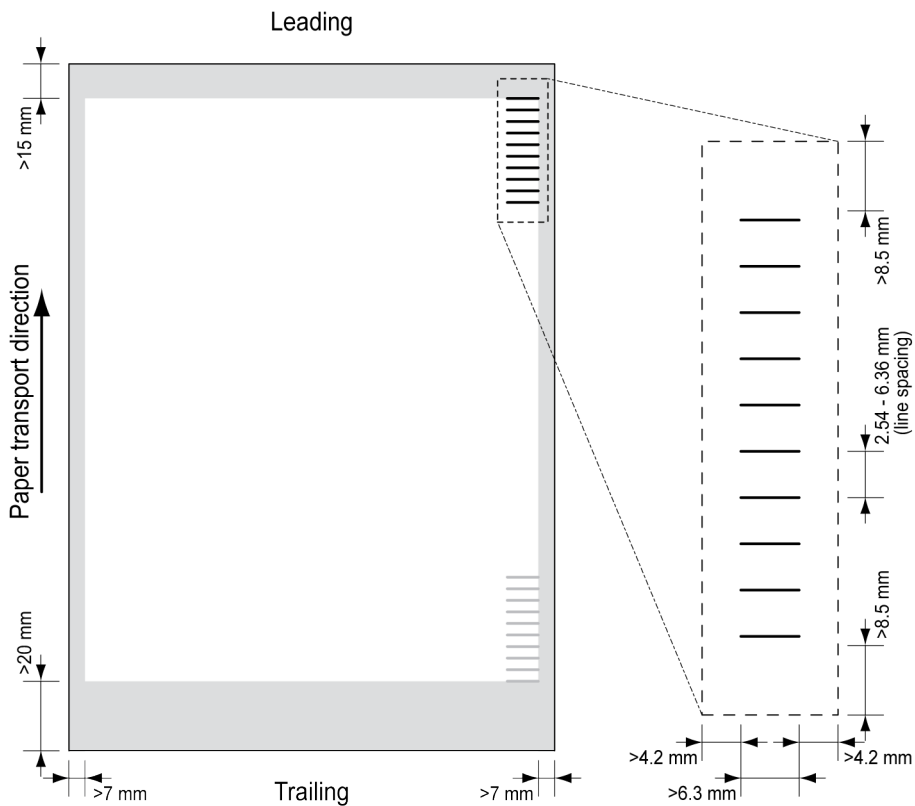

Minimum line thickness of a mark: 0.2 mm (0.008 inch).

Default the first mark from the top is set to: 100 mm (3.9 inch). This parameter is set in the job settings.

The code must have a consistent number of marks on every page.

The white area in the picture shows the limits where the code can be printed.

OMR license types

There are two OMR license types:

- Basic
- Advanced

OMR basic license

For the OMR basic license the following functions are available:

- Start mark: indicates the start of the code.
- Insert/Accumulate: defines when a document set is complete and must be inserted into an envelope.
- Parity check: by adding a parity mark the reading code can be checked. The sum of the marks must be even.
- Safety Mark: is used as an extra security (only 1-track OMR). With skewed paper the reading head can miss part of the reading code. In these situations the safety mark is not read, and the system will give an error. The safety mark also indicates the end of the reading code. This mark must always be present on the document if it is part of the code definition.

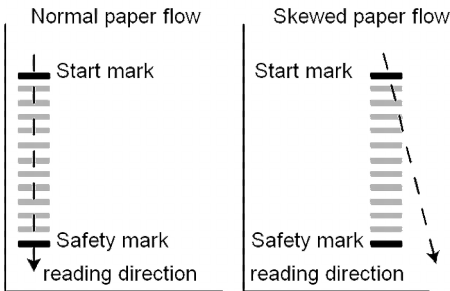

The minimum code is one mark in one line (insert). However for reliability it is advised to use at least 2 marks. The first line is the start mark. A mark printed on the second line means insert. No mark on the second line means accumulate.

OMR advanced license

For the OMR advanced license the following functions are available:

- The basic functions (Start, Insert, Parity, Safety).
- Divert (Divert & Continue) - The set will be diverted and the system continues.
- Stop (Divert & Stop) - The set will be diverted and the system stops indicating error (FT1-RE1-000 Reading stop - Stop mark read).
- Selective Feed (feeder 1-6 and the versaFeeder) - If the system reads the command, an enclosure from the enclosure feeder is added to the set. This function is printed on the last sheet of a set.
- Exit control - Determines if the envelope is transported to stacker or to the side exit.
- Present on deck - The set leaves the system from the upper unit. The system does not stop processing. The envelope is not sealed.
- Present on deck and stop - The set leaves the system from the upper unit. The system stops. The envelope is not sealed.
- Sealing control - Determines if envelopes are sealed or not. If a mark is printed, the envelope is not sealed.
- Sequence Check - Sheets in a stack can accidentally get out of sequence or can be missing. This can be detected by the sequence check. Each sheet has a binary code that is a part of the reading code. Depending on the application one, two or three marks are used by sequence check.

OMR general remarks

General remarks:

- In case of OMR the marks must always be used in the sequence as shown in the figure.

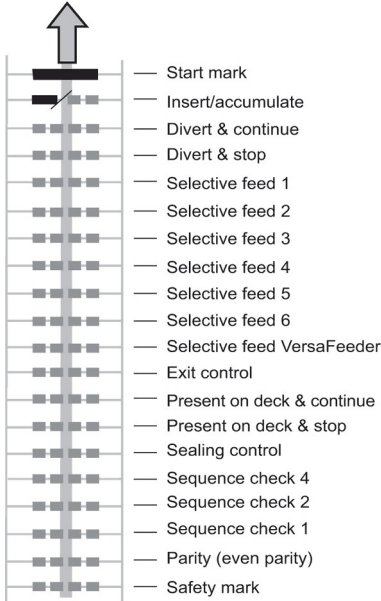

- If a function is suppressed the following function will move upwards one line.
- The mark definition is a service setting.

An Example of OMR Code

In the figure the legend for the following example is shown. In this example, a set of 8 sheets with one selective feed and three sequence check marks is shown.

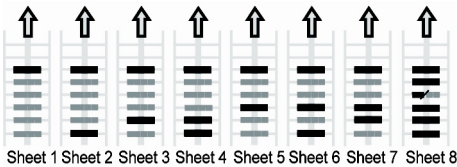

- The first position is used for the start mark which must be printed on every sheet.
- The second mark position is used for the insert/accumulate command. A printed mark means insert, no mark means accumulate. Therefore the mark is printed on the last sheet of the set.
- Position 3 is reserved for selective feed from the enclosure feeder. Print a mark on position 3 when a selective feed from the enclosure feeder is required. The marks are printed on the last sheet of the set.
- Position 4, 5 and 6 are used for the sequence check marks. In this case a three mark sequence check is used.

Flex Reading Code Description

With "Flex reading" also non-standard codes and alternative document handling algorithms can be recognized. Flex reading can be activated by a system specific license code and by a customer specific setting that is saved in a physical dongle.

With Flex three types of reading can be supported:

- OMR
- BCR 1D
- BCR 2D

Depending on the license up to 9 Flex definitions can be used on the system. Creating a Flex job is similar like creating a OMR / BCR reading job.

Create Jobs with Reading

Create a BCR job

To create a job with BCR:

1. From the Job list menu, tap **[New job]**.
2. Choose **[Manual]** to define the job settings.
3. Select an envelope.
4. Tap **[Main document]**.
5. Tap **[Custom]**.
6. Enter the document size or select a standard type.
7. Tap the **[Reading]** tab.
8. Select the code type **[BCR 1D]** or **[BCR 2D]**.

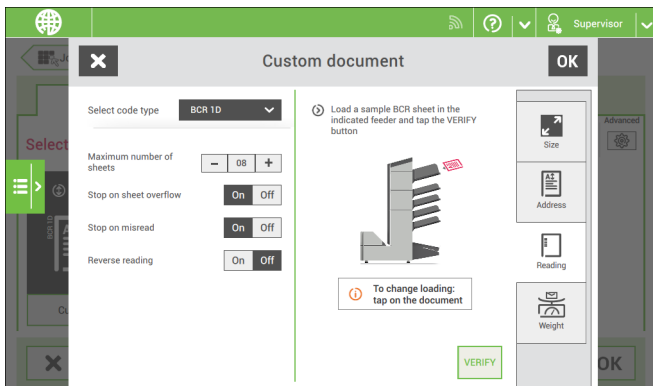

9. Load a sample document in the feeder tray as indicated.
10. Tap **[Verify]** to find the barcode(s) on the sheet.
 - If multiple barcodes are found you can select the correct barcode from the list.
11. Tap **[OK]** and follow the remaining steps to complete the job.
12. When you completed the job creation, tap **[Save]** to save job.

If required the maximum number of sheets can be reconfigured. Refer to [Reading Settings](#) for more details on how to change these settings.

Read a Configuration Sheet

If you want to set the code definition for BCR, use a BCR configuration sheet. The configuration sheet function is available when you are logged on as a [supervisor](#) on page 6.

To read a configuration sheet:

1. Go to the settings menu for supervisor, see [Opening the settings menu \(supervisor\)](#).
2. In the settings menu, tap the **[Reading]** tab.

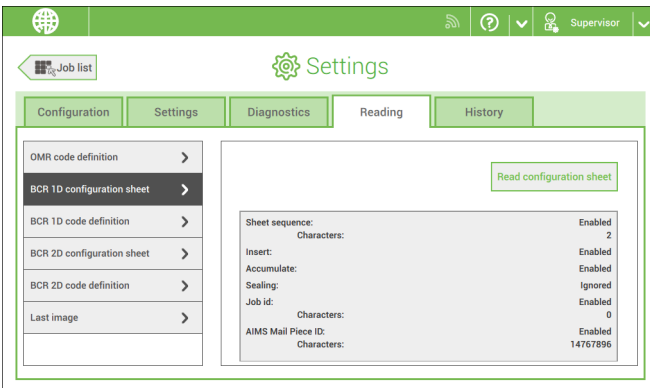

3. Tap **[BCR 1D configuration sheet]** or **[BCR 2D configuration sheet]**.
4. Tap **[Read configuration sheet]**.

5. Load the configuration sheet as indicated and tap **[READ]**.

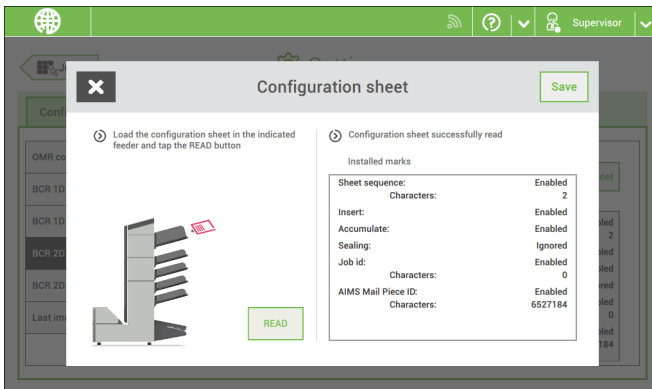

6. Tap **[Save]** to save the new barcode definition.



After reading a configuration sheet, jobs with BCR reading might have changed. These jobs are marked with an exclamation mark, verify the job settings before running the job.

You can also read a configuration sheet when you create or edit a BCR job. The function is available in the side menu.

Create an OMR Job

To create a job with OMR:

1. From the Job list menu, tap **[New job]**.
2. Choose **[Manual]** to define the job settings.
3. Select an envelope.
4. Tap **[Main document]**.
5. Tap **[Custom]**.
6. Enter the document size or select a standard type.

7. Tap the **[Reading]** tab.

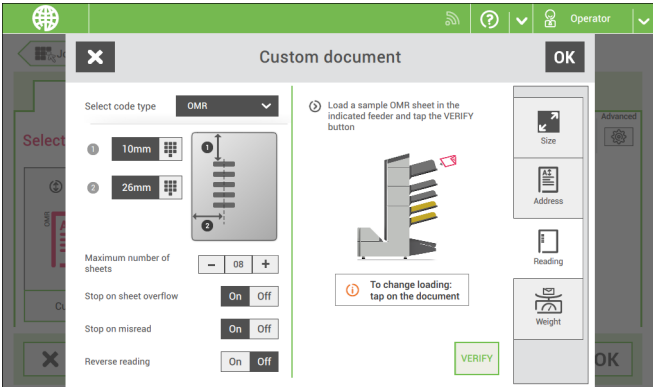

8. Select the code type **[OMR]**.

9. Configure the location of the OMR marks by setting the offset of the top and left side of the sheet.

10. Load a sample document in the feeder tray as indicated.

11. Tap **[Verify]** to read an example sheet to check the correct reading of the OMR marks.

12. If necessary adjust the position from top and from left side. Verify again with a sample sheet.

13. Tap the information button to verify the read OMR marks.

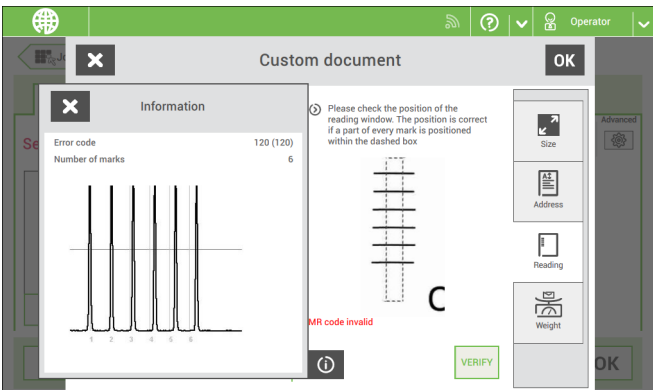

14. Tap **[OK]** and follow the remaining steps to complete the job.

15. When you completed the job creation, tap **[Save]** to save job.

If required the maximum number of sheets can be reconfigured. Refer to [Reading Settings](#) for more details on how to change these settings.

Create a Flex Reading Job

To create a job with Flex reading:

1. From the Job list menu, tap **[New job]**.
2. Choose **[Manual]** to define the job settings.
3. Select an envelope.
4. Tap **[Main document]**.
5. Tap **[Custom]**.
6. Enter the document size or select a standard type.
7. Tap the **[Reading]** tab.
8. Select the code type **[Flex ..]**.



Depending on the flex code type the OMR or BCR settings have to be configured.

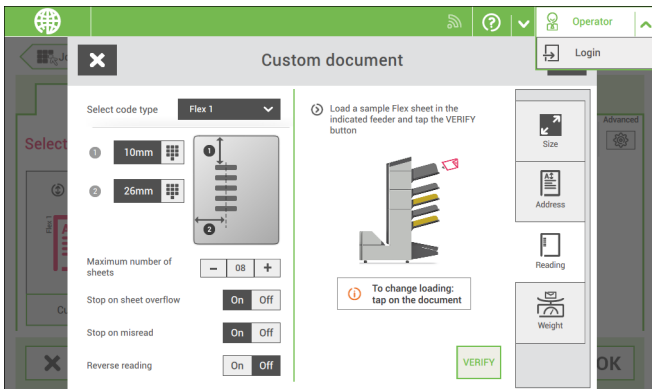

9. Follow the remaining steps to complete the job.

If required the maximum number of sheets can be reconfigured. Refer to [Reading Settings](#) for more details on how to change these settings.

Reading Settings

When you create a reading job for OMR, BCR 1D/2D or Flex reading, the following options can be set:

88

English

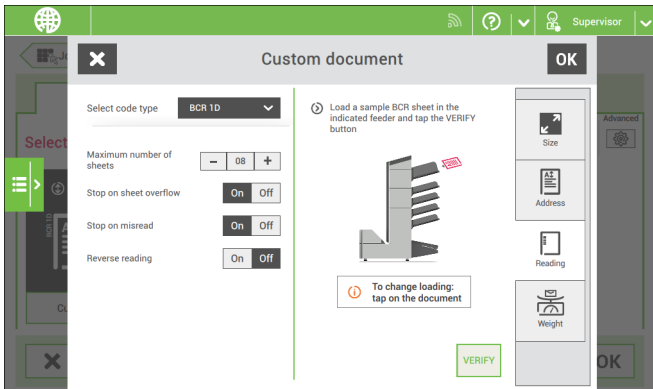

- **Maximum number of sheets:** use the [-] or [+] button to select the maximum amount of sheets in the set of documents.
- **Stop on sheet overflow:** defines if the system should stop or not when a set exceeds the maximum number of sheets, as defined at the "Maximum number of sheets setting".

In case of "on", the system stops when the number is exceeded. The incorrect set is diverted. After resetting the system, the final part of the set is also diverted and the system starts processing again. The diverted set should be checked by the operator.

In case of "off", the system does not stop when a set exceeds the maximum number of sheets. The incorrect set is diverted. The final part of the set is also diverted and then the system starts processing again.

The maximum number of sheets in a set is 25. When the number of sheets exceeds 8 or 10, depending on the fold, the document can not be folded anymore. In this case, the maximum length of sheets is 148 mm for a C5/6 envelope. Also make sure that the fold is set to No fold. Ignoring this will certainly lead to stoppages.



When the maximum number of sheets exceeds the programmed maximum number of sheets in a set, the system stops and error FT1-RE1-312 will be displayed. After removing the set and tapping the **[Start]** button, the system starts and repeats the process until an insert or divert mark is encountered. Error FT1-RE1-003 (final set part) will be displayed.

- **Stop on misread:** defines if the system should stop or not when a code is misread. In case of “**on**”, the system stops after a misread. The incorrect set is diverted. After resetting the system, the final part of the set is also diverted and the system starts processing again. The diverted set should be checked by the operator. When “Stop on misread” is set to “**off**”, the system does not stop after a misread. The incorrect set is diverted. The final part of the set is also diverted and then the system starts processing again. After 5 misreads in a row, the system stops and an error code is generated.

- **Reverse reading:**

With Reverse reading the decision of inserting a mailset is marked on the next set. For example with OMR the insert mark is printed on the first page of the set. The system will detect the end of a set by detecting the first page of the next set. For example in case of BCR using the Customer ID to complete a set. If the ID changes, the set is inserted.

In case the feeder runs empty, the last set is still on the collator because the beginning of the next set could not be detected. In this case the feeder empty message contains an **[Ignore]** function. Tap **[Ignore]** and the set on the collator will be inserted.

Because of the feeding and collating principle reverse reading has the following limitations:

- The last mark of the code should be printed maximally 85 mm (3.3 inch) from the top.
- Enclosures and selective enclosures cannot be handled. When a versaFeeder module is added to the system configuration, enclosures and selective enclosures can be handled with reverse reading.

Exit Selection with Reading

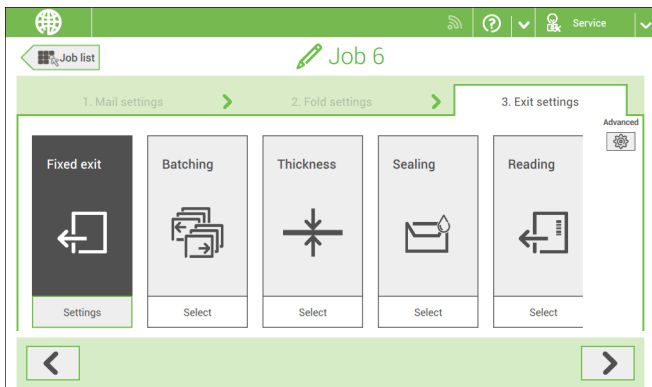

When you have a job with reading, more exit selection options are available:

- **Fixed Exit:** tap **[Settings]** to select which exit must be used for this job. If you select stacker, you can choose to let the system continue on the side exit if the stacker is full.
- **Batching:** tap **[Settings]** to define after what number of mail sets, the system must switch to the other exit. In case of a reading job, you can switch off that the system changes the exit on a reading mark.
- **Thickness:** depending on the thickness of the document set, the envelop exits to the stacker or the side exit. Tap **[Settings]** to define the exit when the mail set is thicker or thinner than the reference. The reference is the first document set.
- **Sealing:** depending on if the envelopes are closed (sealed) or open (not sealed), the envelope exits to the stacker or the side exit. This selection is only possible with reading: no mark (space) means sealed, a mark means not sealed.
- **Reading:** reading has two options: switch exit on mark and let the code define which exit is used. Switch exit on mark means that at every exit code the system changes the exit. If the code defines the exit, you define what happens if the exit code is read: exit code means stacker or exit code means side-exit.
- **Weight:** When using reading the size and weight of the mail set can be different per insert. In order to sort the filled envelopes based on weight, e.g. to stay within a certain postal tariff, the machine can sort the filled envelopes on weight and send them either to the side exit or the stacker.

To enable weight sorting each item in the mail set needs to have a weight configured; the weight of the envelope, main document and possible enclosures have to be set. The machine sums up the total weight of used envelope and documents and compares it with a reference to determine to send the filled envelope to the side exit or the stacker.

9 Operator Maintenance

Maintenance Schedule



Disconnect the mains power supply before performing any maintenance.

The user must not attempt to service the appliance beyond that described in this operator manual. All other servicing must be carried out by qualified service personnel only.

Please contact your authorized distributor.

Maintenance frequency	Maintenance
Daily	<ul style="list-style-type: none">• Check the system functions.• Keep the system in proper condition by removing dust, paper remains, etc.
Weekly	<p>The machine is delivered with an extra set of brushes. To always have one clean set available, it is recommended to soak one set in water and use the other set.</p> <ul style="list-style-type: none">• When dirty or saturated, clean the brushes of the envelope sealing or replace them (see Clean and replace brushes).• When dirty or saturated, clean the moistening cloth or replace if necessary (see Replace moistening cloth).• Clean feed and insert rollers as instructed by the Service Engineer.
When necessary	<p>When the display warns about dusty sensors, clean the applicable sensors. After cleaning, always calibrate the photocells (see Calibrate photocells).</p>

Clean and Replace Brushes

When dirty or saturated, clean the brushes of the envelope sealing or replace them as follows:

1. Moisten the new brushes in water.
2. Lift the unlocking lever A of the upper unit and pull up the upper unit.

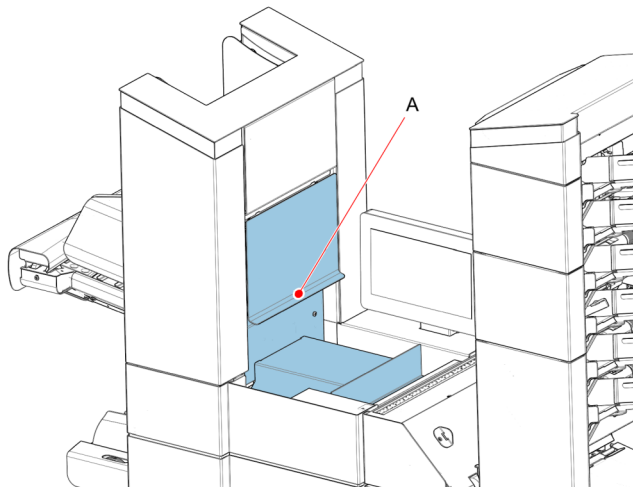

3. Remove the brushes one by one by pulling them down from the brush holder.

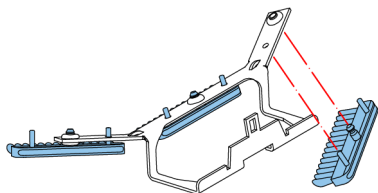

4. Replace the brushes. Make sure that the studs on the brushes are fitted in the corresponding holes in the brush holder.
-

Replace or Clean Moistening Cloth

When dirty or saturated, clean the moistening cloth or replace if necessary. Proceed as follows:

1. Open the front cover **A**.

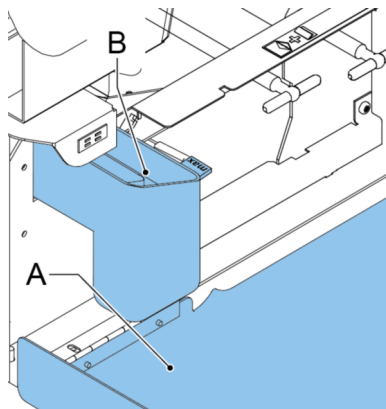

2. Remove the sealing liquid reservoir **B** from the system.
3. Remove the cover with moistening cloth **D**.

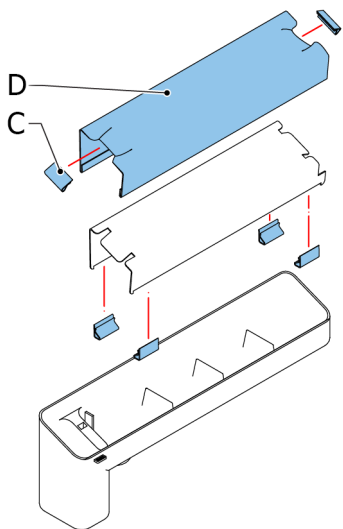

4. Remove clips **C** to remove the moistening cloth.
5. Clean or replace the cloth.

Calibrate Photocells

When too much paper dust is built up at the sensors, a warning message is displayed. In that case, calibrate the photocells as follows:

1. Log in as supervisor.
2. In the settings menu, tap the **[Diagnostics]** tab.
3. Tap **[Maintenance]**.

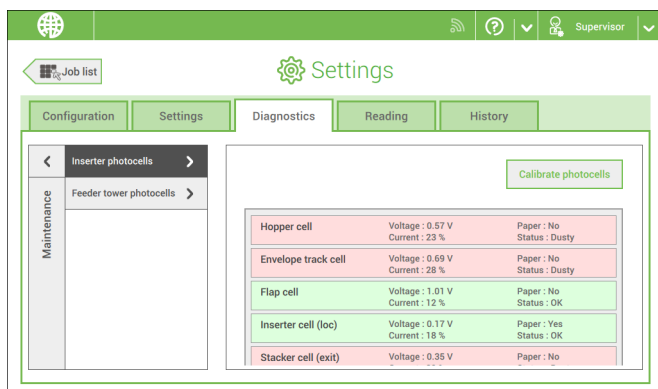

4. Choose which photocells you want to calibrate.
5. Remove all documents and envelopes and close all covers before starting the calibration.
6. Tap **[Calibrate photocells]**.

Warning message

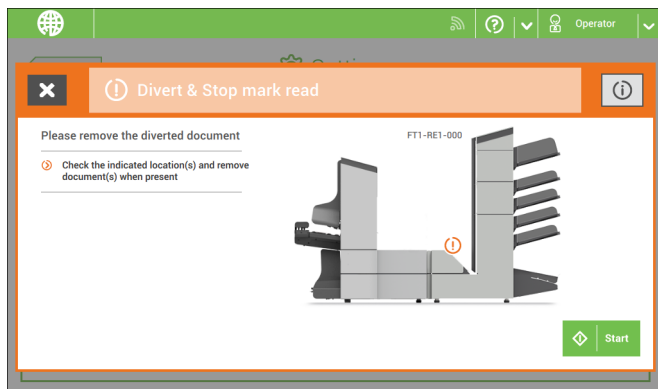

When a warning message is shown, the screen shows the following information:

- An indication of the area in which the event occurred
- A warning description
- A suggested solution behind the arrow
- An event message number; use this number in case that you call support

Tap the **[i]** button to view more information about the event.

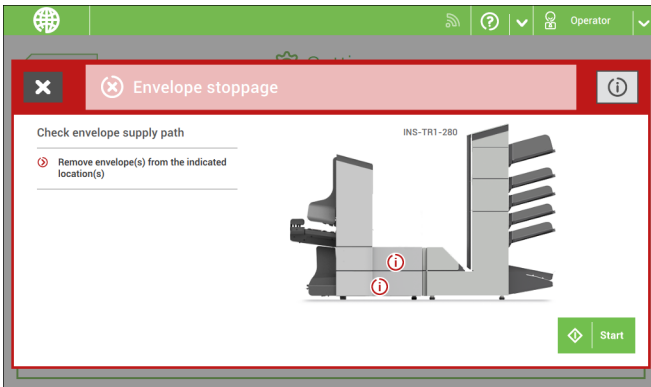

When an error occurs the touch screen shows a screen with the following information:

- An indication of the area in which the error occurred
- An error description
- A suggested solution behind the arrow
- An event message number; use this number in case that you call support

Tap the **[i]** button to view more information about the occurred error and about the possible actions to avoid the error from re-occurring.

After solving the problem, tap **[x]** to reset the error (the error screen will disappear).

Special Errors

- Reading errors (when reading is enabled)
The document set is diverted. The operator must remove the document set and has to complete the set manually!
- Technical errors
The display shows a message. The error cannot be solved by operating personnel and assistance of the service support is needed.

Clearing stoppages

Clear Stoppages

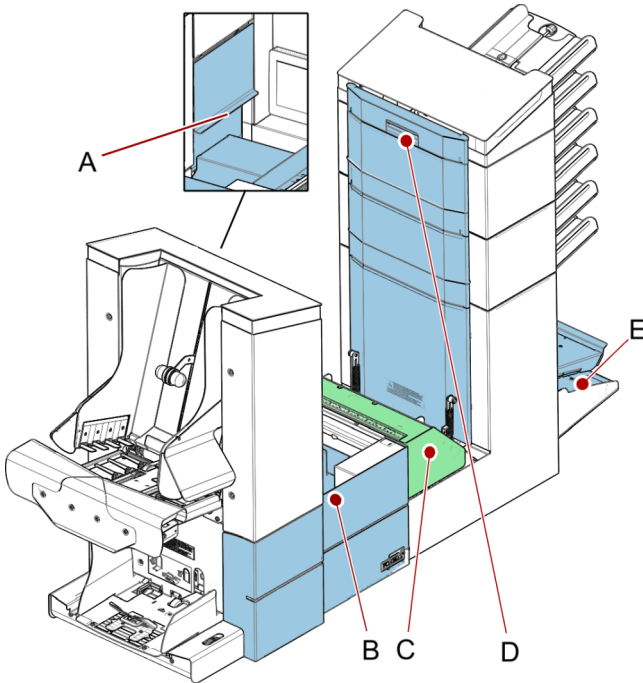

For clearing of stoppages, five system sections can be opened:

- A** - loc, to reach the exit, sealing and inserting area
- B** - side cover, to reach the lower envelope track
- C** - Folder unit cover, to reach the folding area
- D** - vertical transport cover, to reach the vertical transport and feeding area
- E** - collator arm, to reach the collating area

Envelope Hopper

When an envelope gets stuck in the envelope hopper, remove the envelope as follows:

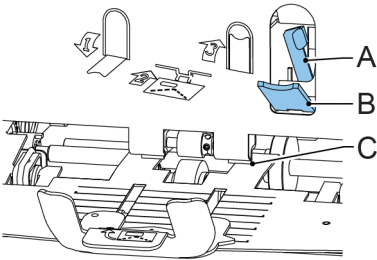

1. Pull down small lever **B**.
Pins **C** will come down.
2. Push lever **A** to the right and hold it.
Pins **C** will go up.
3. Remove the stuck envelope.
4. Release lever **A**.
5. Make sure the separation setting is still correct (see [Loading Envelopes](#)).
6. Return lever **B**.
7. Tap [**x**] to reset the error and restart the job.

Exit, Sealing and Inserting Area

When a stoppage occurs in the exit, sealing and inserting area, remove the material as follows:

1. Lift the unlocking lever A of the upper unit and pull up the upper unit.
 2. Remove all material.
 3. Close the upper unit.
 4. Tap [**x**] to reset the error and restart the job.
-

Lower Envelope Track

When a stoppage occurs in the lower envelope track, remove the envelopes as follows:

1. Open the side cover.
2. Pull down the blue handle **A**.

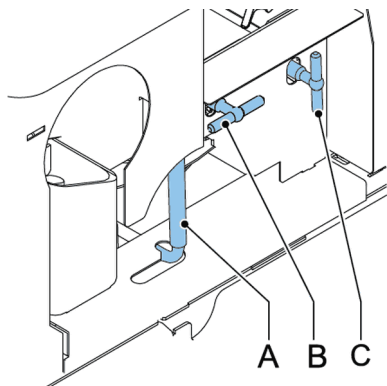

3. Remove the envelope(s) from the lower envelope track.



If needed, envelopes can be transported manually to the insert table or lower envelope track by means of handle **C**. To transport a mail set manually turn handle **B**.

4. Close the side cover.
 5. Tap **[x]** to reset the error and restart the job.
-

Folder unit

When a stoppage occurs in the Folder unit, remove the documents from the Folder unit as follows:

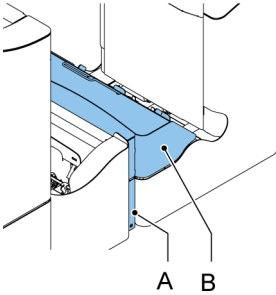

1. Push the lower end of the locking handle **A** to open the Folder unit cover **B**.
2. Remove the documents from the Folder unit.



Use the delivered pin to turn the rollers. The pin is delivered in the spare parts bag.



Remove the pin when finished.

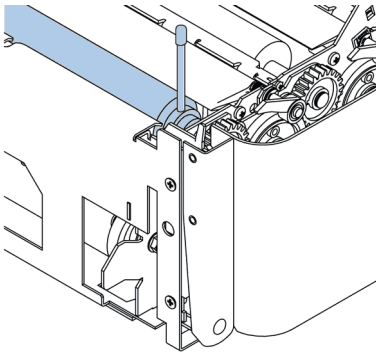

3. Close the Folder unit cover.
4. Tap **[x]** to reset the error and restart the job.

Feeders

When a stoppage occurs in the Feeders, remove the documents from the Feeders as follows:

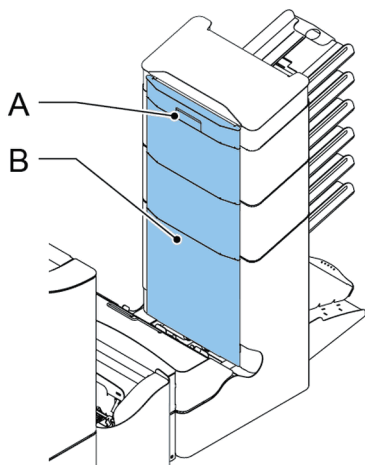

1. Pull the vertical transport hand grip **A** upward to open the vertical transport cover **B**.
 2. Remove the documents.
 3. Close the vertical transport cover **B**: push the bottom side of the cover towards the system, and next the top of the cover.
 4. Tap **[x]** to reset the error and restart the job.
-

Collating Area

When a stoppage occurs in the collating area, remove the documents from the collating area as follows:

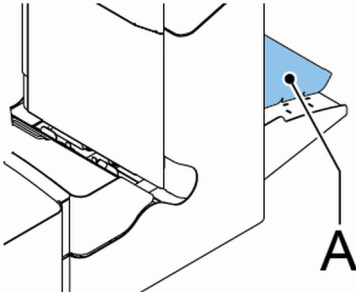

1. Lift and hold the collator arm **A**.
2. Remove the documents.
3. Lower the collator arm.
4. Tap **[x]** to reset the error and restart the job.

versaFeeder

When a document is blocked in the separation unit the document can be removed as follows:

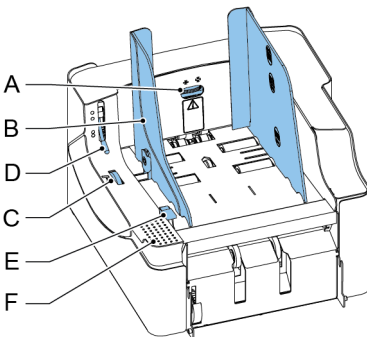

1. Open the separation by placing the release handle **D** in the upper position.

2. Remove the documents.

If necessary open the feed unit:

- Place your hand on the push down area **F**.
- Push down the release handle **E**.

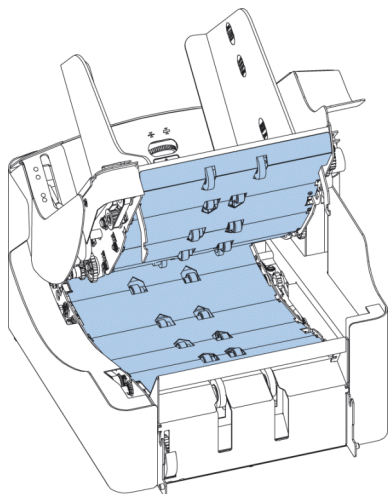

3. Remove the documents from the transportation area and from the rear side of the separation rollers.
4. Close the feed unit:
 - Place your hand on the push down area **F**.
 - Push the feed unit down until it locks into place.
5. Place release handle **D** of the separation unit in the closed position.
6. Tap **[x]** of the error message at the inserter to reset the error and restart the job.

Operator Troubleshooting

To resolve problems:

1. Write down the event message number that is shown in the message on the screen.
2. Try to solve the problem by consulting the Troubleshooting Table.
3. Switch the inserter off and on again, to verify system operation.
4. When the error still occurs contact your service organization.



When contacting the service organization, you will also be asked for the last error message and the software package version of the installed software. To determine the software package version, see Software overview.

Troubleshooting Table

Symptom	Possible cause	Remedy	Reference
The system cannot be started after switching on.	System not connected to mains.	Connect the system to the mains.	-
	Fuse is blown.	Replace fuse below power switch.	-
	A cover is opened.	Close the covers.	-
System stops with envelope at insert position (flap not open).	Envelopes stacked reversed in the hopper.	Check envelope feed adjustments. Place envelopes correctly in hopper.	Loading Envelopes on page 72
	Envelope flap sticks.	Store envelopes according to specifications.	Envelope Specifications on page 145
	Wrong envelope type used (not according to specifications or job settings).	Change envelopes according to specifications.	Envelope Specifications on page 145
Envelopes are double fed.	Envelope separation not correctly set.	Adjust envelope separation.	Loading Envelopes on page 72
	Envelopes not placed properly in the hopper.	Check and replace if needed.	Loading Envelopes on page 72
Envelope stops skewed.	Side guides of the envelope hopper are set too wide.	Check side guides and adjust if needed.	Loading Envelopes on page 72
Envelopes are fed irregularly.	Hopper almost empty.	Refill hopper.	Loading Envelopes on page 72
	Separation set too narrow.	Adjust envelope separation.	Loading Envelopes on page 72
	Side guides set too narrow.	Check side guides and adjust if needed.	Loading Envelopes on page 72
	Envelope support not positioned correctly.	Reposition the envelope support.	Loading Envelopes on page 72

Flap is wrinkled and sometimes not opened.	Envelope not within specifications.	Check specifications and change envelopes if needed.	Envelope Specifications on page 145
	Flap sticks.	Store envelopes according to specifications.	Envelope Specifications on page 145
	Flap curled.	Envelopes stored or manufactured improperly.	Envelope Specifications on page 145
	Separation set too narrow.	Adjust envelope separation.	Loading Envelopes on page 72
Fingers are placed on top of the envelope.	Fingers adjusted too deep into the envelope.	Check fingers position, adjust if needed.	Adjusting the envelope insert fingers on page 43
	Envelope stops too early.	Check envelope stop position, adjust if needed.	Verifying the Insert Position on page 42
System stops while inserting (stoppage at the inserting point).	Fingers not correctly adjusted.	Check fingers position, adjust if needed.	Adjusting the envelope insert fingers on page 43
	Inserted document too long for used envelope.	Check fold settings.	Editing a job on page 51
	Envelope throat incorrect.	Check envelope specifications.	Envelope Specifications on page 145
	Envelope glued inside.	Eliminate faulty envelopes.	-
	Window not glued properly.	Eliminate faulty envelopes.	-

Flap not sufficiently moistened.	Water level low.	Check water level, refill if needed.	Filling the Sealing Liquid Reservoir on page 74
	Brushes dry.	Check brushes, replace if needed by the extra soaked set.	Clean and replace brushes on page 125
	Brushes dirty.	Check brushes, clean if needed.	Clean and replace brushes on page 125
	Moistening felt dry.	Check the moistening felt, refill water tray if needed.	Filling the Sealing Liquid Reservoir on page 74 #
	Moistening felt dirty.	Check the moistening felt, clean if needed.	Replace or clean moistening cloth on page 126
	Brushes worn out.	Replace brushes.	Clean and replace brushes on page 125
	Moistening felt worn out.	Replace moistening felt.	Replace or clean moistening cloth on page 126
Envelope not always ejected from sealer.	Inserted document too big.	Check fold settings, adjust if needed.	Editing a job on page 51
	Document not inserted deep enough.	Check adjustment of envelope stop position and fingers.	Verifying the Insert Position on page 42
	Sealing area dirty.	Clean sealing area.	Maintenance Schedule on page 124

No document fed.	Feeder tray empty.	Refill feeder tray.	Loading documents standard feeder trays on page 61 Loading documents maxiFeeder Loading documents High Capacity Document Feeder on page 68 Loading documents versaFeeder
	Separation set too wide / too tight.	Adjust the separation.	Adjusting the Separation of Special Feeders on page 46 Adjusting the Separation of the maxiFeeder on page 63 Adjusting the Separation of the versaFeeder on page 70
	Side guides set too narrow.	Adjust the side guides.	Adjusting the side guides standard feeder trays on page 59 Adjusting the side guides maxiFeeder on page 62 Adjusting the side guides High Capacity Document Feeder on page 67 Adjusting the side guides versaFeeder on page 69

Skewed documents fed.	Side guides set too wide.	Adjust the side guides.	Adjusting the side guides standard feeder trays on page 59 Adjusting the side guides maxiFeeder on page 62 Adjusting the side guides High Capacity Document Feeder on page 67 Adjusting the side guides versaFeeder on page 69
Double documents fed.	Separation set too wide.	Adjust the separation.	Adjusting the Separation of Special Feeders on page 46 Adjusting the Separation of the maxiFeeder on page 63 Adjusting the Separation of the versaFeeder on page 70
Document set not correctly inserted.	Insert position not correct.	Check insert position.	Verifying the Insert Position on page 42
	Insert fingers not correctly positioned.	Check insert finger position.	Adjusting the envelope insert fingers on page 43
Address not readable from window	Address position not correctly defined.	Check address position.	Adjusting the address position on page 45

11 Specifications

Technical Specifications

Model	DS-95i, FD6608, FPi6700
Type	Folder and inserter system for medium of- fice use.
Theoretical max. speed	4300 inserts per hour, depending on applic- ation.
Maximum number of jobs	50
Power consumption	100V AC/50Hz/4.0 Amps. 115V AC/50/60Hz/4.0 Amps. 230V AC/50Hz/2 Amps.
Voltage tolerance	100V: +6% / -10% 115V: +6% / -10% 230V: +10% / -10%
Fuse	100/115 Vac: T 5.0 A, 125 V . Time lag, 5.0 Amps. rated current, 125 V. 230 Vac: T 3.15 A H, 250 V. Time lag, 3.15 Amps. rated current, high breaking capacity, 250 V.
Approvals	RED (Radio Equipment Directive) 2014/53/EU FCC Certificate conform 47CFR, part 15 CB Certificate conform IEC 62368-1 UL Listed I.T.E. (Information Technology Equipment) Conform UL-IEC 62368-1, file E153801 Conform NEN-EN-IEC 62368-1 and derivat- ives.

Noise Level

71.9 dBA

Measurements based on 1 sheet A4 in C5/6 envelope C-fold application and output to Vertical stacker (US equivalent: 1 sheet letter size in #10 envelope) (according to ISO 11202).

Note: Noise level may vary depending on application.

Operating temperature

10°C - 40°C (50°F-104°F)

Humidity

30%-80%

Hopper and Feeder Capacity

Envelope hopper	400 envelopes (80 g/m ²)
Document feeder tray	325 sheets (80 g/m ²)
High Capacity Document Feeder tray	725 sheets (80 g/m ²)

Configuration Dimensions

	2 stations	3/4 stations	5/6 stations
Height	840 mm (33.1 inch)	840 mm (33.1 inch)	970 mm (38.2 inch)
Width*	460 mm (18.1 inch)	460 mm (18.1 inch)	460 mm (18.1 inch)
Length	1500 mm (59.1 inch)	1500 mm (59.1 inch)	1500 mm (59.1 inch)
Weight	115.5 kg (255 lbs)	123 kg (271 lbs)	137.0 kg (302 lbs)

* Width with catch tray 750 mm (29.5 inch)

* Length with one versaFeeder 2000 mm (77.7 inch), with two versaFeeders 2500 mm (98.4 inch)

Document and Insert Specifications

Paper quality	Minimum 60 g/m ² (15 lb bond) Maximum 250 g/m ² (62.5 lb bond), when folded max. 170 g/m ² (42.5 lb bond) Booklets up to approximately 2 mm (0.08 inch) thickness, depending on stiffness
Paper size	Minimum width: 130 mm (5.1") Maximum width: 242 mm (9.5"), when folded 230 mm (9.1") Minimum length: 90 mm (3.5") Maximum length: 356 mm (14")
Folding capacity	V-fold - 10 sheets (max. 80 g/m ²) C-fold/Z-fold - 8 sheets (max. 80 g/m ²) Double V-fold - 4 sheets (max. 80 g/m ²)
Envelope sizes	Standard BRE (Business Reply Envelopes)
Envelope quality	Minimum 80 g/m ² (20 lb bond) Maximum 120 g/m ² (30 lb bond)

Envelope and Document Set Specifications



When choosing envelopes ensure the envelope size is well between the maximum and minimum specification. Envelopes close to the minimum or maximum size specification are likely not to be the best performing envelopes. Contact your local distributor for advice on the best performing envelopes for your system.

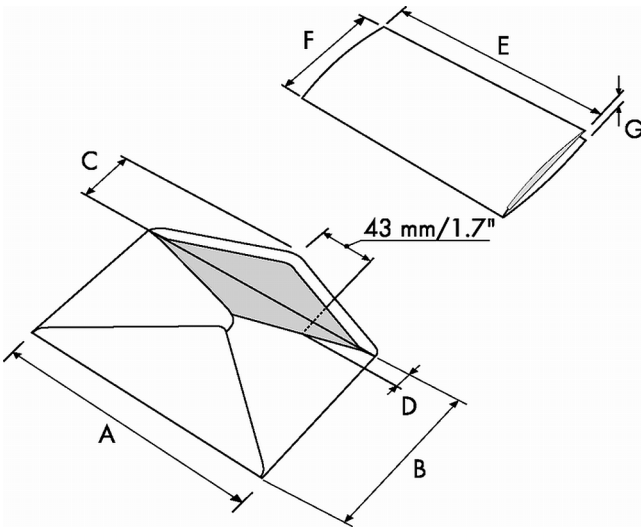

	A	B	C	D	E	F	G
Minimum size	160 mm 6.3"	90 mm 3.5"	32 mm 1.25"	10 mm 0.4"	130mm 5.1"	84 mm 3.3"	60 g/m ²
Maximum size	248 mm 9.7"	162 mm 6.38"	B-32 B-1.25	35 mm 1.38"	A-12* A-0.47**	B-6 B-0.2	3 mm 0.1"

* Booklets up to approximately 2 mm (0.08 inch) thickness, depending on stiffness

** When insert is more than 1 mm (0.04 inch): A-15 mm / A-0.6 inch

Envelope quality	
Minimum	80 g/m ² (20 lb bond)
Maximum	120 g/m ² (30 lb bond)

Remarks:

- The specification of the paper handling equipment is often wider than that of the envelopes and documents handled. The condition of material handled will limit the specified environmental conditions.
- We recommend that materials to be handled are stored at a temperature of 20°C (68°F) with a relative humidity factor of 50%. If difference in temperature occurs between store room and mailing area, the material has to be stored near the machine at least 24 hours before use.

- Self-copying paper may cause rubber parts to wear quicker. The rubber used in this machine has the best resistance to Wiggins Teape material.

maxiFeeder Specifications

Model	Model MF-4
Type	High capacity feeder
Theoretical max. speed	see Technical Specifications
Power consumption	Low voltage supplied by the inserter system.
Approvals	EMC Certificate conform EMC-Directive. FCC Certificate conform 47CFR, part 15. UL Listed I.T.E. (Information Technology Equipment), conform UL-IEC 62368-1, file: E153801. Conform EN-IEC 62368-1 and derivatives.
Height	210 mm (8.3 inch)
Width	285 mm (11.2 inch)
Length	425 mm (16.7 inch)
Weight	5.05 kg (11.1 lbs)
Noise level	see Technical Specifications
Operating temperature	10°C - 40°C (50°F-104°F)
Humidity	30%-80%
Feed tray capacity	1200 sheets A5 80 gr. 325x Business Reply Envelopes
Feed tray capacity 356 mm-Licensed	1200 sheets A4 80 gr. 325x Business Reply Envelopes
Document / BRE insert specifications	See Document Specifications and Envelope Specifications

versaFeeder Specifications

Model	VF-4
Type	Booklet feeding device for medium office use
Theoretical max. speed	4300 inserts per hour, depending on application.
Power consumption	100V AC/50Hz/2.0 A 115V AC/50/60Hz/2.0 A 230V AC/50Hz/1 A
Approvals	EMC Certificate conform EMC-Directive. FCC Certificate conform 47CFR, part 15. CB Certificate conform IEC 62368-1. UL Listed I.T.E. (Information Technology Equipment), conform UL-IEC 62368-1, file: E153801. Conform EN-IEC 62368-1 and derivatives.
Height	407 mm (16.0 inch)
Width	440 mm (17.3 inch)
Length	500 mm (19.7 inch)
Weight	31 kg (68.3 lbs)
Noise level	Lp < 68 dB(A) ± 2 dB(A) (ISO 7779/DIN EN 2779 part 7)
Operating temperature	10°C - 40°C (50°F-104°F)
Humidity	30%-80%
Paper quality, feed unit	Minimum 80 g/m ² (15 lb bond) single sheets (max. 500 sheets) Booklets up to approximately 2.5 mm (0.09") thickness
Paper quality, transport unit	Minimum 60 g/m ² (15 lb bond) Thickness up to 3.2 mm (0.13")

Document size	<p>Minimum width: 120 mm (4.7")</p> <p>Maximum width: 243 mm (9.6")</p> <p>Minimum length: 90 mm (3.5")</p> <p>Maximum length: 162 mm (6.4")</p>
Hopper tray capacity	<p>Booklets with a tough cover: maximum height 250 mm</p> <p>Booklets with a weak cover: maximum height 150 mm</p> <p>Single sheets (80 gr/m²): maximum height 50 mm</p>

12 Terminology

Terminology

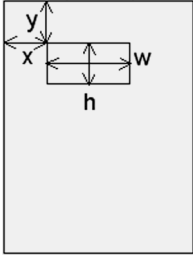
Term	Description
Address carrier	The address carrier is the document that carries the address of the person for who the mail-set is meant. The address must remain visible while enclosures are added and the document-set is folded. The fold type and selected envelope must ensure that the address is visible behind the window in the envelope. For personalized mailings there is always an address carrier present as long as envelope printing is not supported. Normally there is one address carrier.
Address position	 <p>Position of the address on the address carrier, measured from the upper left corner. The address position consists of a horizontal x coordinate, a vertical y coordinate, a horizontal width w and a vertical height h.</p>
Automatic	The feature of an Inserting System to automatically determine its Job settings by measuring the sizes of documents and envelope. From all Feeders that are loaded one sheet will be taken. Based on the maximum document length (which is also the length of the documentset) and the length of the envelope the fold type is determined.
Automatic job	A job that is created with the Automatic functionality.
Barcode Reading (BCR)	Barcode Reading is intended for reading and interpreting printed barcodes. The codes give information to the Inserting system about how to build-up and handle a set.
Business Reply Envelope (BRE)	Envelope included in outgoing mail-sets for addressee response purposes.

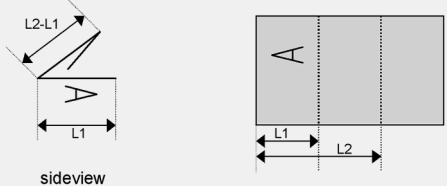
C-fold	<p>Fold type in which a document-set is folded twice in which the folded flaps are on top of each other. This fold is illustrated in the picture below.</p>  <p>The position of both folds is adjustable. Synonym: Letter fold.</p>
Clear	<p>The function of an inserting system in which all mail-sets in progress are finished and the document path is left empty.</p>
Daily Mail	<p>Capability of an inserting system to manually insert mail-sets one by one into the system, which are then inserted into an envelope. Optionally, depending on settings, additional enclosures can be added and the mail-set can be folded. This function is intended for small amounts of mail that each can have a different build-up.</p>
Divert area	<p>To avoid stoppages the Divert area diverts duplicate or faulty documents before folding them while the system is still running.</p>
Document	<p>A document is one of the components of a mail-set. A document can consist of one or more sheets. Documents can be divided into address carriers and enclosures. For personalized mailings there is always one address carrier and an optional number of enclosures.</p>
Document-set	<p>The document-set is the physical collection of address carrier and enclosure(s) that is under production in the Inserting System. The document-set is completed during production and is to be inserted in the envelope. The number of enclosures can range from 0 to the limit opposed by the number of available Feeders. Once the document set has been inserted into an envelope it is called mail set.</p>
Double Feed Control (DFC)	<p>Double Feed Control is the sensor that measures the thickness of a sheet to check if the inserting system does not accidentally take more sheets than intended. DFC sensors exist on Feeders (double sheet detection). Currently DFCs on inserting systems perform relative measurements, which means that they need a cycle to 'learn' the thickness of a sheet. Also the length of the document is measured so partly overlapping sheets will be detected.</p>
Double parallel fold	<p>See double V-fold.</p>

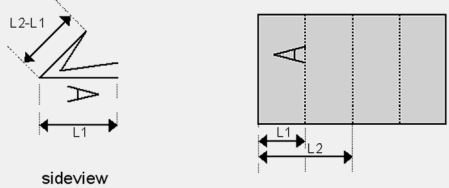
Double V-fold	<p>The double V-fold is a type of fold where the document is first folded halfway and the resulting folded set is again folded halfway. This fold is illustrated in the picture below.</p>  <p>The position of both folds is adjustable. Synonym: double parallel fold.</p>
Envelope	<p>The envelope is the packaging of a mail set. Window envelopes are envelopes that have a transparent section through which the address on the address carrier can be read. Besides the normal top-closing window envelopes there are also bottom-closing envelopes.</p>
Extended Folding	<p>Option, makes bottom address applications and short folds possible.</p>
Face down	<p>Situation in which the front of a sheet is facing downwards when placed in a document feeder.</p>
Face down leading	<p>Situation in which the front of a sheet is facing downwards and the top of the sheet is closest to the separation unit in a document feeder.</p>
Face down trailing	<p>Situation in which the front of a sheet is facing downwards and the bottom of the sheet is closest to the separation unit in a document feeder.</p>
Face up	<p>Situation in which the front of a sheet is facing upwards when placed in a document feeder.</p>
Face up leading	<p>Situation in which the front of a sheet is facing upwards and the top of the sheet is closest to the separation unit in a document feeder.</p>
Face up trailing	<p>Situation in which the front of a sheet is facing upwards and the bottom of the sheet is closest to the separation unit in a document feeder.</p>
Feeder(s)	<p>The (document) feeding part of the system. A Feeder is a Module for the input of documents to the inserting system. The Feeder separates documents sheet by sheet from the stack of documents in the feed tray.</p>
Feeder linking	<p>The ability to load two feeders with the same document type where the Inserting System automatically switches to a second feeder when the first feeder is empty and vice versa. In the mean time the first feeder can be refilled, so the inserting system can keep running without having to stop for refilling the feeders.</p>

Feed tray	Part of the feeder that contains the stack of documents.
Flexcode OMR	An OMR code for which the meaning of the OMR marks can be programmed in a dedicated way for a specific customer. This is normally used to support the OMR codes from other suppliers.
High Capacity Document Feeder (HCDF)	Optional feeder with a capacity for up to 725 sheets.
High Capacity Vertical Stacker (HCVS)	Optional stacker that is mounted on the exit of the system, to stack filled envelopes.
Insert	<ul style="list-style-type: none"> • An insert is the action of inserting a document-set into an envelope. • For native English speaking customers an insert is also a short, not to be folded document, usually an enclosure.
Inserter	An Inserter is the Module where the document-set is inserted into the envelope, the envelope is closed and if necessary sealed.
Inserting system	The system of all the Modules that cooperate to perform the inserting function (accumulate document-set, fold and insert) and have a single point of control.
insert'n Frank / insert'n Mail (mailing machine)	Interface for the franking machine.
Job	<p>A job is an actually produced collection of mail-sets based on a certain Job Definition at a certain point in time for a specific purpose. It consists of:</p> <ul style="list-style-type: none"> • The Job definition used for the production • Information about the batch size
Job counter	The counter that registers the number of mail-sets that is produced as part of a specific job.
Letter fold	See C-fold.
Linking	See Feeder Linking.
Loc	The Loc is the unit in the system that transports the envelope just after the document was inserted. It is called Loc (short for locomotive) as the early developments had a straight cover and a number of transportation rollers sticking out. This made it look like a locomotive from the side. In the current systems the loc also carries the brush holder and sealing rollers.

Maxifeeder	Feeder with high capacity feed tray (e.g. 1200 sheets A4 80gr).
Multifeed	The feature of an Inserting System in which more than one sheet is taken from a Feeder.
OMR	Optical Mark Recognition
OMR code definition	Standard 1-track OMR code definition. Specifies the amount of reading marks used and the functionality linked to each of them (how each should be interpreted).
Operator	The person operating a document system.
Optical Mark Recognition (OMR)	Optical Mark Recognition is intended for reading and interpreting printed codes. These codes are one or more black marks which are read from a document. These marks give information to the Inserting system about how to build-up and handle a set.
Folder unit	The Folder unit can fold up tot 10 pages.
Reading error	Condition in which the system could not reliably read or interpret the OMR reading marks or barcode from a sheet.
Reading marks	Marks added to documents containing finishing instructions that can be identified by a reading head and interpreted according to the used OMR code definition.
Remote diagnostics	The feature that makes it is possible to analyze a problem on an Inserting System from a remote location.
Service engineer	Technical engineer whose task it is to resolve problems with systems in the field. Besides dealing with problems, service engineers are also responsible for preventive maintenance.
Single fold	See V-fold.
Stop counter	Counter which sets the amount of envelopes to be filled. After filling this amount of envelopes the system will stop (even during a clear).
Supervisor	Person who is responsible for the technical state of the machine. Normally a supervisor has access to programming functions, which are restricted for standard users.
Test run	A test run is intended to validate the settings of the Inserting System: <ul style="list-style-type: none"> • Inspect and adjust the stop position of the envelope. • Check the fold settings for one set. • Check if the address is correctly positioned behind the envelope window.
Thickness detection	Checks the thickness of the document set. If the thickness is less or more than the set value an error message is displayed.

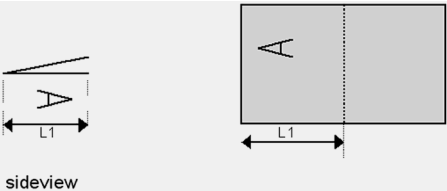
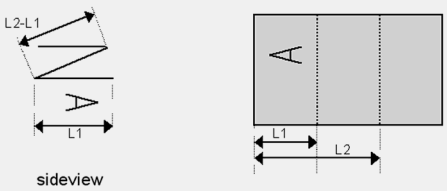
Tray	Contains a stack of paper for a printer or inserter. This paper is supplied to the machine for further processing.
V-fold	<p>A V-fold implies the document/set is folded once. The fold-position is adjustable. This fold is illustrated in the picture below:</p>  <p>sideview</p> <p>Synonym: Single fold.</p>
Vertical transport	The vertical transport section between feeders and collator.
Z-fold	<p>A Z-fold means that a document is folded twice in such a way that each folded flap is on a different size of the folded document, resulting in a Z-shape. This fold is illustrated in the picture below.</p>  <p>sideview</p> <p>The position of both folds is adjustable. Synonyms: zigzag fold</p>